

# FiXed Piloting Unit

Piloting unit



# Europe



- Approved by the Panama Canal authority
- Equipped with the latest Global Navigation Satellite System
- Integrated UPS with hot-standby
- High accuracy motion measurement



### Category

All vessels with a beam of  $\geq 109$  feet



Deepsea

# Features |

Effective on October 1, 2023, all vessels with a beam of 109 feet (neopanamax vessel) or more transiting the Panama Canal will be required to have a fixed piloting unit with Real Time Kinematics (RTK) for submeter accuracy on board. This measure is expected to improve the efficiency of the waterway by eliminating the delays associated with the installation of portable piloting units (PPU-RTK).

JRC can offer you a unit equipped with the latest Global Navigation Satellite System (GNSS) technologies. Our JRC Europe FiXed Piloting Unit is currently approved by the Panama Canal authority. Once the unit is installed and powered, it will provide the required communication with the pilot's tablet and the software via wireless network. The FiXed Piloting Unit ensures a stable and long-range connection in all conning positions during the transit through the Panama Canal, even in a total black-out, it will stay alive for at least 5 hours.

## System overview |

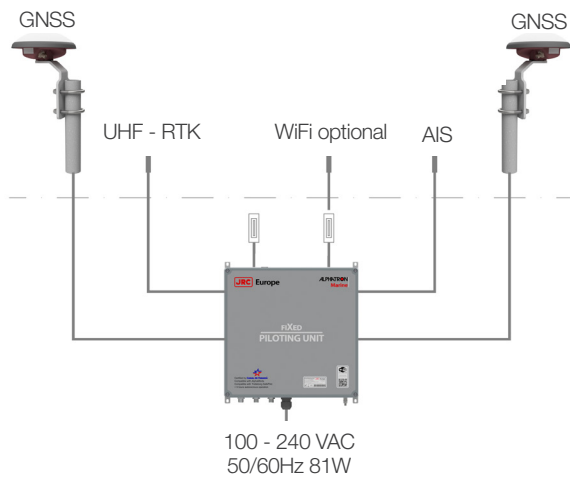

- Full GNSS Precision Antennas
- High gain over the full GNSS spectrum
- State of the art CT-104 GNSS-receivers
- Real time kinematics (RTK) technology
- Dual channel AIS receiver
- UHF receiver for DGNSS corrections
- High accuracy motion measurement (IMU) with a Gyro Bias Instability  $\leq 1.1^\circ/\text{hr}$
- Two Wi-Fi antennas for indoor use, optional outdoor antennas available



## In the box

FiXed Piloting Unit

G-022206

Consists of:

- A sturdy enclosure with integrated modular equipment and a UPS
- Two high-precision GNSS antennas\*
- Two Wi-Fi antennas for indoor use\*
- One VHF antenna for AIS\*
- One UHF antenna for RTK\*
- Antenna brackets for outdoor antennas

\* Antenna cables are not included



## Optional

Outdoor WLAN antenna

G-022235

AlphaMINDS Docking bundle

G-009374

# Specifications |

## Fixed piloting unit

The FiXed Piloting Unit will house two GNSS receivers with latest technology, AIS and UHF receivers in a sturdy enclosure. The stand-alone unit will communicate through Wi-Fi with the pilot's tablet and the software, using a unique unit ID, providing the relevant navigation data.

Furthermore, the main unit will feature a power switch and a visual indicator to switch off the equipment while sailing outside the Panama Canal. However, the integrated UPS will have a hot-standby, which allows it to charge always, and capacity is available when needed. The FiXed Piloting Unit also provides possibilities to be connected with and used by other navigation software and not bonded to be used strictly for the Panama Canal requirement.

### Features

Power switch	On/ off with visual indicator
Power supply	90 - 240 VAC
UPS	Battery Backup: ≥ 5 hours of operation

### Interfaces

W-LAN	2 x N- Connector – Wi-Fi communication: <ul style="list-style-type: none"><li>• Standard 2x Indoor antenna</li><li>• Optional:<ul style="list-style-type: none"><li>• 1x Indoor antenna</li><li>• 1x Outdoor antenna</li></ul></li></ul>
UHF	1 x N- Connector – UHF DGNSS correction reception
VHF	1 x N- Connector - AIS reception
GNSS	2 x N- Connector - GNSS reception

### Mechanical

Dimensions (WxHxD)	401 x 406 x 201 mm
Weight	20 kg

### Environmental

Operating Temperature	-5°C ~ +55°C
IP-rating	IP66

# Specifications |

## Non-portable piloting unit unique ID

For a seamless and easy connection, we will provide the main unit with a QR code. This QR code will include ID, SSID & password.



GNSS Antenna				
Constellations		GPS/QZSS-L1/L2/L5, QZSS-L6, GLONASS-G1/G2/G3, Galileo-E1/E5a/E5b/E6, BeiDou-B1/B2/B2a/B3, NavIC-L5+ L-band correction services		
LNA Gain		37 dB min.		
Noise Figure		1.8 dB typ. @ 25 °C		
VSWR		< 1.5:1 typ.   1.8:1 max.		
GNSS Receiver				
Received signals (184-channels)		GPS L1C/A L2C, GLONASS L1OF L2OF, Galileo E1B/C E5b, BeiDou B1I B2I, QZSS L1C/A L1S L2C, SBAS L1C/A		
Nav. update rate		RTK 8Hz (up to 20 Hz <sup>1</sup> )		
Position accuracy <sup>2</sup>		RTK 0,05 m + 1 ppm CEP		
Convergence time <sup>2</sup>		RTK < 10 sec		
Anti-jamming		Active CW detection and removal onboard band pass filter		
Anti-spoofing		Advanced anti-spoofing algorithms		
Inertial Measurement Unit (IMU)				
Gyro Bias Instability		≤ 1.1°/hr		
Angular Random Walk		≤ 0.08°/√hr		
6 Degree OF Freedom		Triple gyroscopes		
Antennas		Frequency	VSWR	Gain
UHF		445 - 470 MHz	< 1.5	3 dB
VHF		146 - 162.5 MHz	< 1.5	3 dB
Wi-Fi IEEE 802.11 (WLAN) a/b/g/h/j/n/p/ac	Indoor	2400 - 2495 MHz 4910 - 5925 MHz	Low Band < 2.0:1 High Band < 1.5:1	0 dBd
	Outdoor		< 2.0:1	9 dB
WLAN				
Standard		IEEE 802.11b/g/n		
Security		WPA/WPA2, WPA-PSK, Support Open System, Shared KeyWEP/		
Firewall		Includes SPI, Anti-DoS Attack, Filtering Multicast, Ping package, Access Control List (ACL), NAT, PAT, DMZ		
Maximum number of clients		User defined (at most 128)		
Data output				
NMEA output		GGA, VTG, HDT, ROT, GSA, GSV, VDM		
Data Protocol		Compatible with SafePilot		
PTMSX messages		Contain unique vendor ID and unique equipment ID		

<sup>1</sup> The highest navigation rate can limit the number of supported constellations.

<sup>2</sup> Depends on atmospheric conditions, baseline length, GNSS antenna, multipath conditions, satellite visibility, and geometry.



[jrc-europe.com](http://jrc-europe.com)

Head office

JRC/Alphatron Marine B.V.  
Schaardijk 23  
3063 NH Rotterdam  
The Netherlands  
+31 10 453 4000  
[sales@jrc-europe.com](mailto:sales@jrc-europe.com)

Worldwide

Belgium	Malaysia
Curaçao	The Netherlands
France	Poland
Germany	Singapore
Japan	Spain
Korea	USA