



Change Over Box

Type 138-119

Operator- and Service-Manual

- 1 Description**
- 2 Function of the Change Over Box**
- 3 Installation and Stetting to Work**
- 4 Change Over Box in the STD22-System**
- 5 Maintenance and Repair**

Weitergabe sowie Vervielfältigung dieser Unterlage, Verwertung und Mitteilung ihres Inhaltes nicht gestattet, soweit nicht ausdrücklich zugestanden. Zuwiderhandlungen verpflichten zu Schadenersatz.

Toute communication ou reproduction de ce document, toute exploitation ou communication de son contenu sont interdites, sauf autorisation expresse. Tout manquement à cette règle est illicite et expose son auteur au versement de dommages et intérêts.

Copying of this document, and giving it to others and the use or communication of the contents thereof, are forbidden without express authority. Offenders are liable to the payment of damages.

Sin nuestra expresa autorización, queda terminantemente prohibida la reproducción total o parcial de este documento, así como su uso indebido y/o su exhibición o comunicación a terceros. De los infractores se exigirá el correspondiente resarcimiento de daños y perjuicios.

SAFETY INFORMATION



Caution!

Pay attention whilst Maintenance and Repair. Avoid contact with cable under load. Adhere to respective safety regulations, as there are VDE, BGV A2, OSHA 1919 and other national and international safety standards.

This Change Over Box is not equipped with an interlocking mechanism.

Before Maintenance or Repair the device has to be separated from supply voltage.



ATTENTION!

Maintenance and Repair have to be performed only by trained personnel, which is familiar with the safety requests of this device.



Determinations for handling of electrostatic devices must be adhered to.

To remove or to add an assembly or a printed circuit board under load may lead to severe faults of the device.

Insert no fuses with other technical data than the prescribed ones.

Change Over Box 138-119



COMMERCIAL NOTES

Change Over Box in application with GG-R and GGM-R

- ▶ Not all Status messages/Alarms are displayed at the Operator Unit. It has to be assured that all the alarm-contacts of both Distribution Units (system Failure) are connected to an external Alarm Units.
- ▶ The DV-Bus is not switched-over by the Change Over Box.
- ▶ A difference alarm (G/G or G/M) does not lead to a switch-over in the Change Over Box.
- ▶ At one of the two Operator Units the automatic switch-over-function G -> G or G -> M has to be set. Thus ensures a switching -over from a failed selected sensor to the next heading sensor in function.
- ▶ Connected repeater should be configured in such a manner, that heading from a gyro is as well indicated as heading from a magnetic sonde.
- ▶ Information and/or data to operate the compass have to be stored twice (for each Distribution Unit), by operating the Change over Switch into the respective position.



SAFETY INFORMATION and Notes		I
1	Description	1
1.1	Change Over Box Type 138-119	1
1.2	Change Over Switch Type 124-187	3
1.3	Technical Data	4
1.3.1	Change Over Box	4
1.3.2	Change Over Switch	4
2	Principle of function Change Over Box	5
2.1	Principle "Change Over Box in the STD22-System"	5
2.1.1	Switch position "Automatic"	8
2.1.2	Switch position "System 1"	9
2.1.3	Switch position "System 2"	9
3	Installation and Setting to Work	11
3.1	General Comments	11
3.1.1	General remarks to establish cable connections	13
3.1.2	General information about establishing an earth connection	15
3.2	Connecting the Change Over Box to the STD22-System	16
3.2.1	Connecting the supply voltage	16
3.2.1.1	Voltage supply of the connected receiver	16
3.2.2	Connecting of signal lines	17
3.3	Setting to work	19
3.3.1	Special features for operating a system with a Change over Box	20
3.3.1.1	Special features for DV bus operation	20
3.3.1.2	Special features for connected Rate Gyro	21
3.3.1.3	Special features for connected NAV Manager/ Data Manager	21
3.4	Function test of Change Over Box and Change Over Switch	22
3.5	Switching OFF the Change Over Box	23
4	Change Over Box application in the STD22-System	24
4.1	Change Over Box application in the STD22 GG-R Gyro Compass System	24
4.2	Change Over Box application in the STD22 GGM-R Gyro Compass System	26
4.3	Redundant Voltage Supply	28
4.4	Error message "System Failure"	29
4.4.1	"System Failure" in switch position "Automatic"	30
4.4.2	"System Failure" in switch positions "Sys1" and "Sys2"	31
4.4.3	Status messages/ Error messages	32
5	Maintenance and Repair	34
5.1	Maintenance	34
5.2	Repair	34
5.2.1	Safety instructions	34
5.2.2	Trouble shooting in a STD22 Gyro Compass System	35
5.2.3	Fuses in the Change Over Box	35
5.2.4	Service	36
5.2.4.1	Exchanging of fuses	37
5.2.4.2	Exchanging of relays	38
5.3	Parts list	38

Change Over Box
138-119

6	Error performance	39
6.1	Gyro 1 fails	40
6.2	Gyro 2 fails	41
6.3	Distribution Unit 1 fails	41
6.4	Distribution Unit 2 fails	41
6.5	Power Supply 1 fails	42
6.6	Power Supply 2 fails	42
6.7	Magnetic sonde 1 fails	43
6.8	Magnetic sonde 2 fails	43

Drawings

Change Over Box	Dimensional Drawing	138-119.HP005
Change Over Box	Bauschaltplan / Wiring Diagram	138-119.HP008
Change Over Switch	Dimensional Drawing	124-187.HP005
Block diagram STD 22 GGM-R, Signal flow		10-BD-D-X00014-C
Block diagram STD 22 GG-R, Power Distribution		10-BD-D-X00013-C

1 Description

1.1 Change Over Box Type 138-119

The Change Over Box Type 138-119 is used to operate redundantly two compass-systems.

It serves to switch-over automatically or manually of up to 12 different signals.

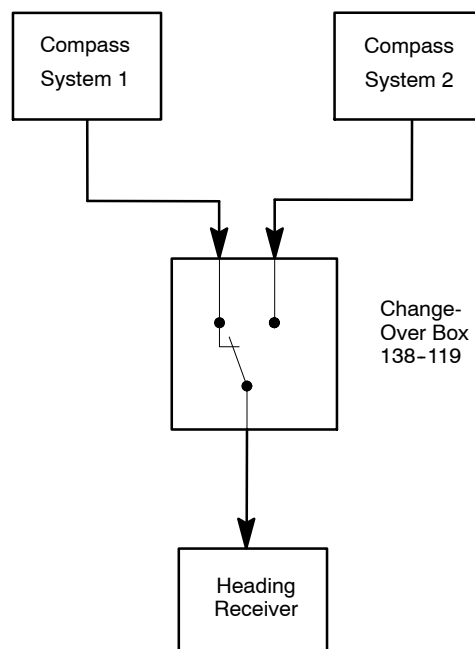
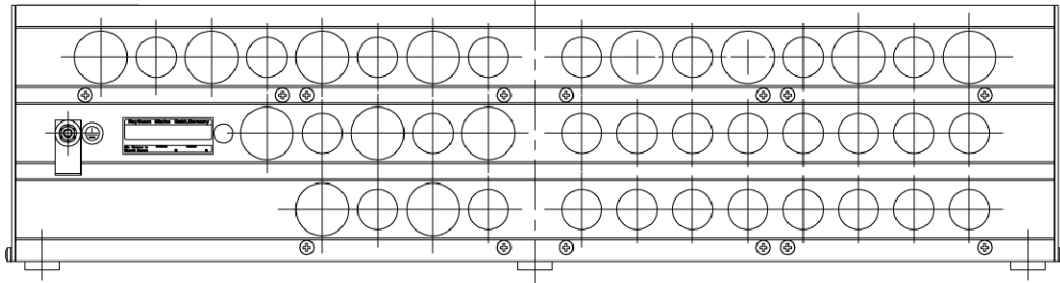

Figure 1: Principle of switching-over

Change Over Box 138-119

Bottom view



top view

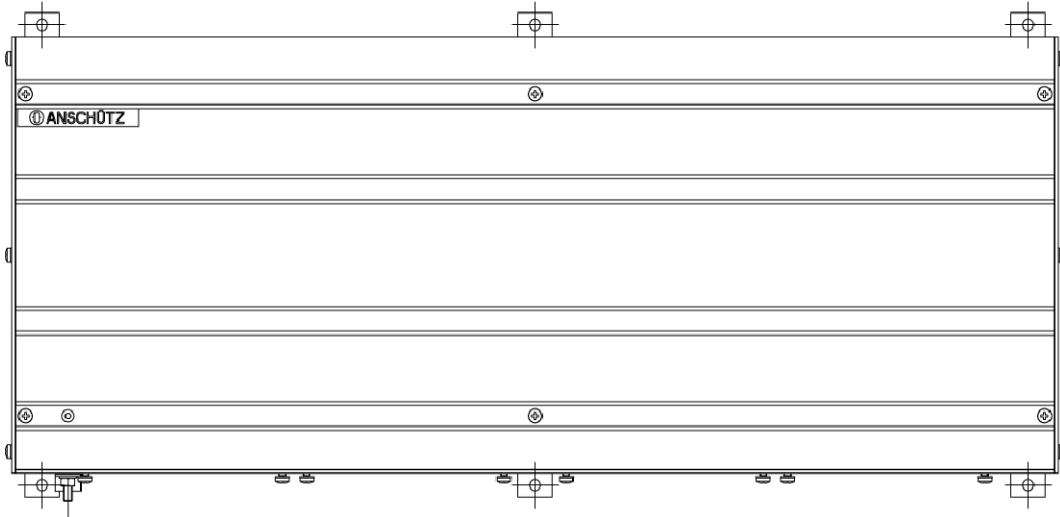

Figure 2: Change Over Box Type 138-119

1.2 Change Over Switch Type 124-187

The Change Over Switch Type 124-187 is applied in combination with the Change Over Box to allow the redundant operation (standard operation) of the compass equipment (Change Over Switch position “Automatic”). During standard operation a switching-over to the other system takes place if a fault occurs.

By manual switching-over to position “Sys1” or “Sys2” signal outputs are assigned to the respective Distribution unit constantly.

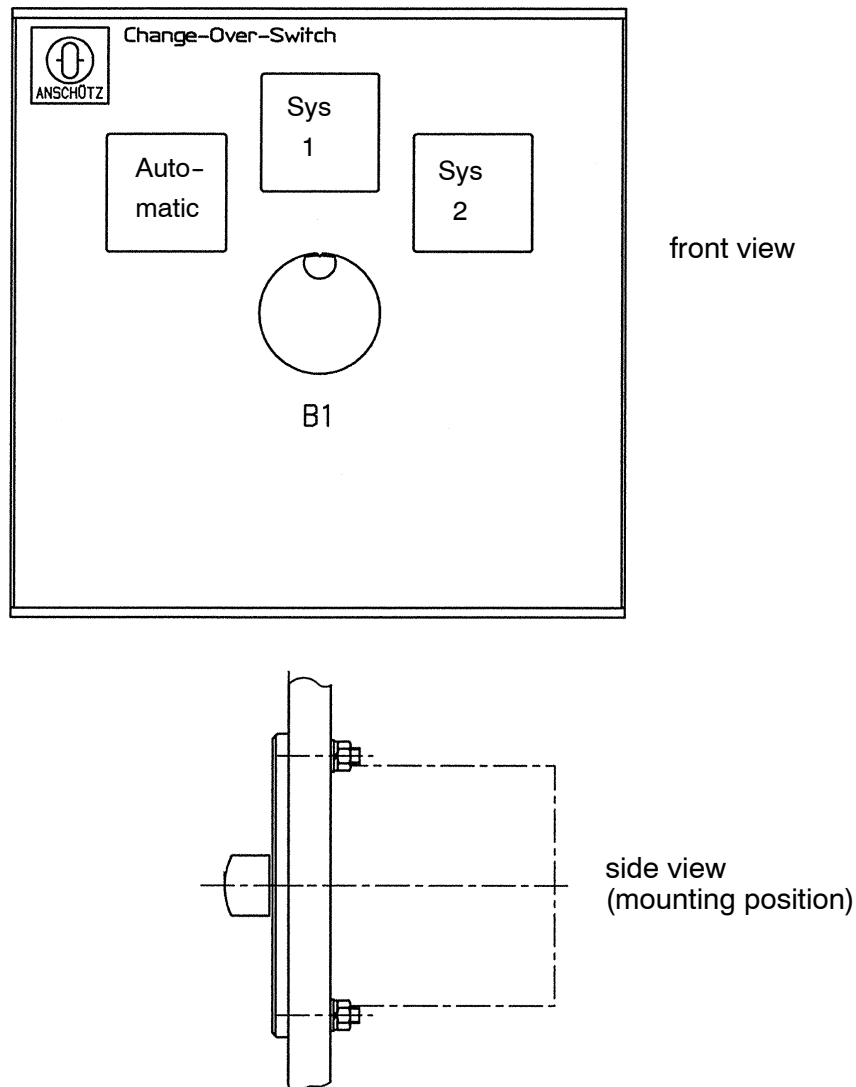

Figure 3: Change Over Switch Type 124-187

Change Over Box 138-119

1.3 Technical Data

1.3.1 Change Over Box

See also Change Over Box Dimensional Drawing 138-119.HP005 at the appendix.

- Dimensions: appr. 605 mm x153 mm x250 mm
- Weight: appr. 8 kg

- Mounting mode: Wall mounted

- Internal Protection: IP22
(Wall mounted, Cable inlet below)

- Main Fuse (Terminal board): 2 x T10 A, 250 V

- Nominal voltage range (Relays) 18 - 36 V_{DC}

- Operating voltage (Mains supply) 24 V_{DC}

- Power consumption (Relays) max. 1 A

- Number of Relays 18 (3 Relay-Groups with 6 Relays each)

- Number of Relay contacts 4 nc* and 4 no* for each Relay
(in total 72)

*nc - normally closed, no - normally open

1.3.2 Change Over Switch

The Change Over Switch is a 4-pole switch with three switch-positions.

- Dimensions appr. 96 mm x120 mm x96 mm
- Weight appr. 0.8 kg

2 Principle of function of the Change Over Box

2.1 Principle "Change Over Box in the STD 22-System"

In the redundant system of the Standard STD 22 the Change Over Box and the Change Over Switch are used to switch-over between the output signals of both systems. The diagram below shows the principle of switching-over including the fault monitoring of Compass system 1.

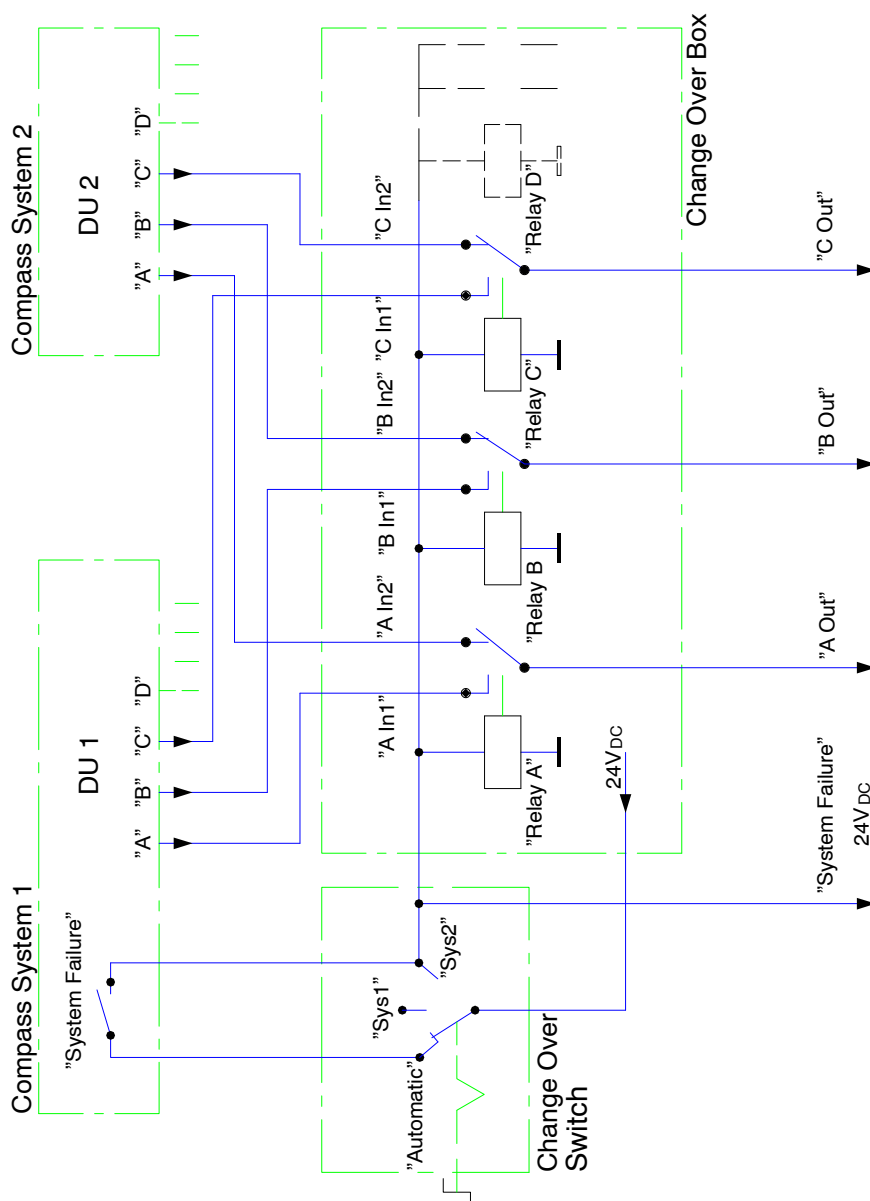

Figure 4: Principle of switching-over in the compass system STD 22

Change Over Box 138-119

Caption:

“A”	=	Signal “A”
“B”	=	Signal “B”
“A In1”	=	Signal “A” at the output “System 1”
“B In2”	=	Signal “B” at the output “System 2”
“A Out”	=	switched signal “A”
“B Out”	=	switched signal “B”
“System Failure”	=	Failure message of “compass system 1”



NOTE

Some of the relay outputs are led via fuses from the Change Over Box to the connected receivers. This fuse protection serves to prevent effects to the Change Over Box in case of a fault in a connected heading receiver.

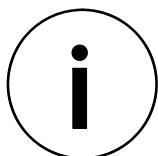

NOTE!

A.m. Figure 4 shows a principle of switch-over. The actual connections are shown in the appended wiring diagrams.

The switch-over-relays in the Change Over Box are controlled with a switching voltage of 24 V DC. This switching voltage is generated in the Change Over Box, led to the Change Over Switch.

The operation of the Change Over Box is possible with three different switch positions:

- Automatic switch-over because of a fail.
- Manual switch-over to system 1.
- Manual switch-over to system 2.

Change Over Box
138-119



COMPASS
STD22

Below mentioned table shows an overview of the possible switch positions and the appertaining operation modes.

Pos.	Switch position	Mode	Status
1	"Auto-matic"	"Normal mode"	- Output of "System 1" at the outputs of the Change Over Box. - In case of a fault in "System 1" - switching-over to "System 2"
2	"Sys1"	"System 1"	- Output of "System 1" at the outputs of the Change Over Box.
3	"Sys2"	"System 2"	- Output of "System 2" at the outputs of the Change Over Box.

Further information to the switching positions is given in the following sections.

Change Over Box 138-119

2.1.1 Switch position “Automatic”

In the normal mode (switch position “Automatic”) the switching-over of the output signals of compass system 1 are carried out of the Distribution Box (DU1) via the Change Over Box (see Figure 4).

All relays of the Change Over Box are dropped out. The DUs of both compass systems communicate via the CAN bus. But only the DU1 is “active” and its output signals (“A In1”, “B In2” etc.) are switched to the connected receiver (“A Out”, “B Out” etc.).

If a fault is detected in the DU1 (“System Failure”), the Change Over Box switches over to the DU2 automatically. This is affected by closing the contact of relay “System Failure” in the DU1. Thus the 24 V DC switching voltage is switched to the Change Over Box via the Change Over Switch.

All relays of the Change Over Box operate and switch the outputs of the Change Over Box from the signal outputs of the DU1 (for example “A In1”) to the signal outputs of the DU2 (for example “A In2”).

At the same time the error message “System Failure” can be detached as a 24 V DC potential from the Change Over Switch for external applications.

This switch-over function is not activated by a fault in the Distribution Unit 2.

After repair and setting into operation again the output signals of the compass system 1 are switched to the output of the Change Over Box, No additional measures are necessary.



ATTENTION!

It can happen that there is a desynchronisation of the 6-steps/degree signal after switching-over – either manual or automatically.

2.1.2 Switch position “System 1”

If the Change Over Switch is switched into position “Sys 1” manually, the signal outputs of the compass system 1 are carried out of the Distribution Box via the Switch Over Box (see Figure 4).

The connection of the relay “System Failure” of system 1 (DU 1) via the Change Over Switch is not used. The 24 V DC potential is not switched to the relays of the Change Over Box. All relays are dropped out.



ATTENTION!

There is no automatic switch-over to DU 2 if the DU1 fails (“System Failure”).

The Change Over Box does not switch signals from the outputs of the Distribution Unit 1 to the heading receivers.

2.1.3 Switch position “System 2”

If the Change Over Switch is switched into position “Sys 2” manually, the signal outputs of the compass system 2 are carried out of the Distribution Box via the Switch Over Box (see Figure 4). The connection of the relay “System Failure” of system 2 (DU 2) via the Change Over Switch is not used. The 24 V DC potential is fed from the Change Over Box via the Change Over Switch and back again to the Change Over Box. All relays operate.



ATTENTION!

There is no automatic switch-over to DU 1 if the DU2 fails (“System Failure”).

The Change Over Box does not switch signals from the outputs of the Distribution Unit 2 to the heading receivers.

**Change Over Box
138-119**

intentionally left blank

3 Installation and Setting to Work

3.1 General Comments



Caution!

During installation, ensure that there are no live cables. If necessary, carry out measurements and switch off the respective power distribution.

ATTENTION!

Installation is to be performed only by trained personnel, which is familiar with the safety requirements of this device.

Installation of the Change Over Box and the Change Over Switch have to be performed according to appended wiring diagrams.

Change Over Box 138-119

For installation of the Change Over Box see Dimensional Drawing 138-119.HP005.

Additional criteria for the mounting location:

- The Change Over Box may not be installed within an oil vapour area.
- Not down in the bilge.
- Keep distance to other equipment to perform cabling to the Change Over Box.
- The cover of the Change Over Box has to be removable to the front
- The attachment has to be seaworthy, shock-proof and resistant to vibrations.
- The Change Over Box may not be exposed to dripping water (according to its internal protection IP 22 - cable inlets below-).

3.1.1 General remarks to establish cable connections



NOTE!
While closing again the housing after a repair or an installation, the cover has to be set carefully.
The seal may not be crushed, if necessary push the sidewall slightly.

In order to ensure that the system operates correctly, it is essential to follow the procedures described below for establishing cable connections.

1. Strip off approx. 180 mm of the cable (depending on the distance terminal board or relay to the cable inlet).
Make sure not to damage the shielding.
2. Strip off the shielding to a remainder of approx. 15 mm.

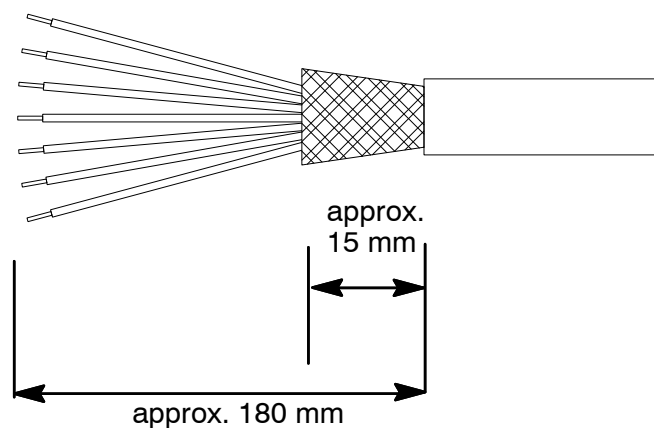

Figure 5: How to strip a connection cable

Change Over Box 138-119

3. Screw the cable gland out from the Change Over Box and push the screw connection components over the cable.

It is absolutely necessary that the sequence (as shown in Figure 6) is adhered to.

4. Check the cone and counterpart on the earthing insert for corrosion and if necessary remove corrosion using an appropriate process (emery board).
5. Push the counterpart of the earthing insert as far as the end of the cable shield.
6. Push the earthing insert cone below the shielding against the counterpart.

Make sure that the shielding is evenly over the cone.

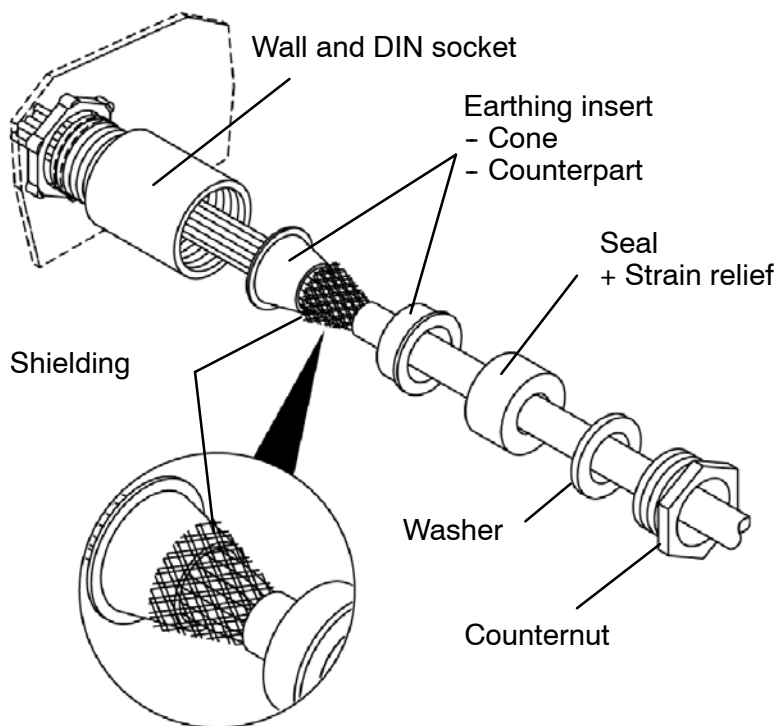



Figure 6: Making a cable entry

7. Insert the earthing insert, the seal with and the washer into the cable gland, place the counter nut on top and hand-tighten.
8. Strip the cable cores to a length of approx. 15 mm, twist slightly and clamp on the cable end sleeves. Connect the cable strands in the Change Over Box as shown in the appended wiring diagrams. Hand-tighten the terminal screws concerned.
9. Check the connection is firm by pulling slightly.

3.1.2 General information about establishing an earth connection

In order to comply with the stringent EMC requirements, please abide by the information given below regarding cable connections.

Use the cable types specified in the appended wiring diagrams.



ATTENTION!
It is essential to ensure that these connections have a common reference to ship's earth.
Any additional components (options - if there are) must also be connected to the common earth!

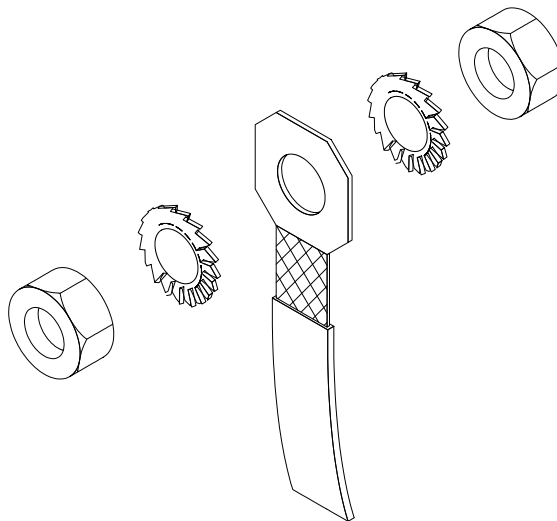

Figure 7: Establishing an earth connection

All earth connections must be made as shown in Figure 7

- The earthing cable attached to the bracket must have a cross-section of minimum 1,5 mm².
- The cable bracket should be mounted between two toothed washers.
- Earth connections must be free of corrosion and well fastened.

Change Over Box 138-119

3.2 Connecting the Change Over Box to the STD22-System

Detailed terminal designations, cable connections, cable types are to be established according to the wiring diagram (138-119.HP008), the actual cable and connection diagrams as well as the manual of the Distribution Unit 138-118.

3.2.1 Connecting the supply voltage

(see also section 4.3 - Redundant voltage supply).

Voltage supply is effected by connecting the 24 V DC supply voltage via 2 fuses (6,3 A, 24 V) to the terminal board of the Change Over Box.

(see also Change Over Box wiring Diagram 138-119.HP008).

3.2.1.1 Voltage supply of the connected receiver

The connected receivers can be supplied with operating voltage (24 V DC) out of the Change Over Box independent of the signal lines.

For that purpose supply lines to the receivers have to be connected at the terminal board (terminals 3 to 13) of the Change Over Box. These terminals are fuse-protected.

Terminals 3 to 10 are fitted with fuses 1 A, 24 V (it is to connect the supply voltage for only one receiver).

Terminal 11 to 13 are fitted with fuses 2 A, 24 V (it is to connect the supply voltage for up to two receivers).

3.2.2 Connecting of the signal lines

The output signal lines of DU 1 are connected to the break contact element of the respective relay, because of a switching through of the dropped-out relay status.

The output signal lines of DU 2 are connected to the normally open contacts of the relay, because of lead over from the Change Over Box after switching-over to the activated switching status.

All relays are activated at the same time (with applying the switch-over voltage).

There is no assignment of the signal lines to the relays.



ATTENTION!

While connecting the signal lines it is important to pay attention that identical signal outputs of the Distribution Units have to be connected to the same relay.

Change Over Box 138-119

Below mentioned output signals can be switched-over from the Change Over Box:

- up to 12 (8) serial outputs (Anschütz course bus or NMEA)
- 3 x Step (6 steps/degree) 24 / 35 V_{DC}, max. 10 W
- 1 x rate of turn +/- 10 V for 30/100/300 degree/minute
- 1 x RS 232 serial printer interface
- 2 x Switching status of the Change Over Box

The total amount of relay contacts is shown in the table below:

No.	Signal outputs	Type of signal	Number of outputs	Number of lines per signal
1	Serial outputs (Anschütz course bus or NMEA)	TX+ TX- GND	up to 12	3
2	Step (6 steps/degree)	S1, S2, S3, +35 V, 0 V	3	5
3	Rate Of Turn	RoT Aus RoT GND	1	2
4	Serial printer interface	TX GND	1	2
5	System Failure DU 1 (2)	Status	2	1

3.3 Setting to work

There is no ON/OFF-switch at the Change Over Box.
There are no indicating elements.

The only operating element of the Change Over Box is the external Change Over Switch.

By operating the Change Over Switch the Change Over Box is switched into the desired operation mode



NOTE!

The Change Over Box has to be set to work only with switch position "Automatic".

The normal mode of the Change Over Switch is the switch position "Automatic", only in exceptional cases it should be switched to "Sys1" or "Sys 2".

One of these exceptional cases is a non static error in the Compass system 1.

In this case an always changing error would activate a switch-over between system 1 and system 2. By manual switching into position "system 2", this unstable status is cancelled.

By switching ON one of the two power supplies (AC/DC-Converter 24 V DC) of the STD22-system, the Change Over Box is set to work. Normally, both power supplies are connected and switched ON.

After heating and settling time (see respective compass manual) of both compasses the system is in operation.

Change Over Box 138-119

3.3.1 Special features for operating a system with a Change over Box

3.3.1.1 Special features for DV bus operation

To prepare both Distribution Units for an operation at a DVB-bus, they have to be set while the CAN bus is active (for each Distribution Unit separate).

It means:

Switch Change Over Switch into position "Sys1".

Activate the DV bus at the Operator Unit (see respective manual)

The Distribution Unit 1 is set to operate with DV bus application.

Switch Change Over Switch into position "Sys2".

Activate the DV bus at the Operator Unit (see respective manual)

The Distribution Unit 2 is set to operate with DV bus application.

Switch Change Over Switch into position "Automatic" .



Note!

This setting is permanently stored in the respective Distribution Unit.

After a replacement or a software-update of a Distribution Unit, above mentioned procedure has to be repeated for both Distribution Units.

3.3.1.2 Special features for connected Rate Gyro

It is possible to connect Rate Gyros to the Distribution Units.

Settings for the Rate Gyros can be made at the respective Distribution Unit (scaling) and at the Operator Unit (selection).

If a connected Rate Gyro fails, the Rate of Turn of the actual selected Gyro is automatically took over.

The blackout of the external connected Rate Gyro is recognized only at the Operation Unit in the service menu (see also Operator Unit manual) no.: 3648.



To monitor a blackout of an external connected Rate Gyro, the respective alarm contact of the Rate Gyro has to be analysed respectively be connected to an external alarm device.

If the Rate Gyro becomes active again, the Rate of Turn is automatically took over from the Rate Gyro.

3.3.1.3 Special features for connected NAV Manager/Data Manager

While configuring a NAV Manager/Data Manager it has to pay attention to set for all received position and speed data the tests for checksum and header to "ACTIVE".

If both tests are not active, than faulty data are corrected and are forwarded as "not faulty".

Change Over Box 138-119

3.4 Function test of Change Over Box and Change Over Switch

This function test has to be performed :

1. After first setting to work of the Change Over Box.
2. After a repair of the compass systems.
3. During a maintenance procedure of the Change Over Box (see section 5.1)

The function test has to be performed during the operation of the system, it means the supply voltage for the system is switched ON. To monitor the LEDs of each relay, the cover has to be removed during the function test.



ATTENTION!

Pay attention during Maintenance and Repair. Avoid contact with live cables. Adhere to respective safety regulations, as there are VDE, BGV A2, OSHA 1919 and other national and international safety standards.

ATTENTION!

Maintenance and Repair have to be performed only by trained personnel, which is familiar with the safety requirement of this device.

Removal of spare parts is not allowed at a system under load.



CAUTION!

Do not perform a function test during a sea trial.



Below mentioned tests have to be carried out:

No.	Action	Nominal state
1	Switch the Change Over Switch from "Automatic" to "Sys1".	No LED lights up at the relays of the Change Over Box. All outputs of the DU1 are switched to the outputs of the Change Over Box.
2	Switch the Change Over Switch from position "Sys1" to position "Sys2".	All LED LEDs light up at the relays of the Change Over Box. All outputs of the DU2 are switched to the outputs of the Change Over Box.
3	Switch the Change Over Switch from "Sys2" to "Automatic".	No LED lights up at the relays of the Change Over Box. All outputs of the DU1 are switched to the outputs of the Change Over Box.

If errors should occur during the function test, appropriate measures have to be seized for repair.

3.5 Switching OFF the Change Over Box

The Change Over Box has no ON/OFF switch.

The Change Over Box is shut down by switching OFF both 24 V DC power supplies.

A single Change Over Box can be switched OFF by disconnection of one fuse E1 or E2.

Change Over Box 138-119

4 Change Over Box application in the STD22-System

4.1 Change Over Box application in the STD22 GG-R Gyro Compass System

The block diagram below shows a Change Over Box and a Change Over Switch in the STD22 GG-R Gyro Compass System (GG-R = Gyro/Gyro - Redundant) (see also block diagram 10-BD-D-X00013-C).

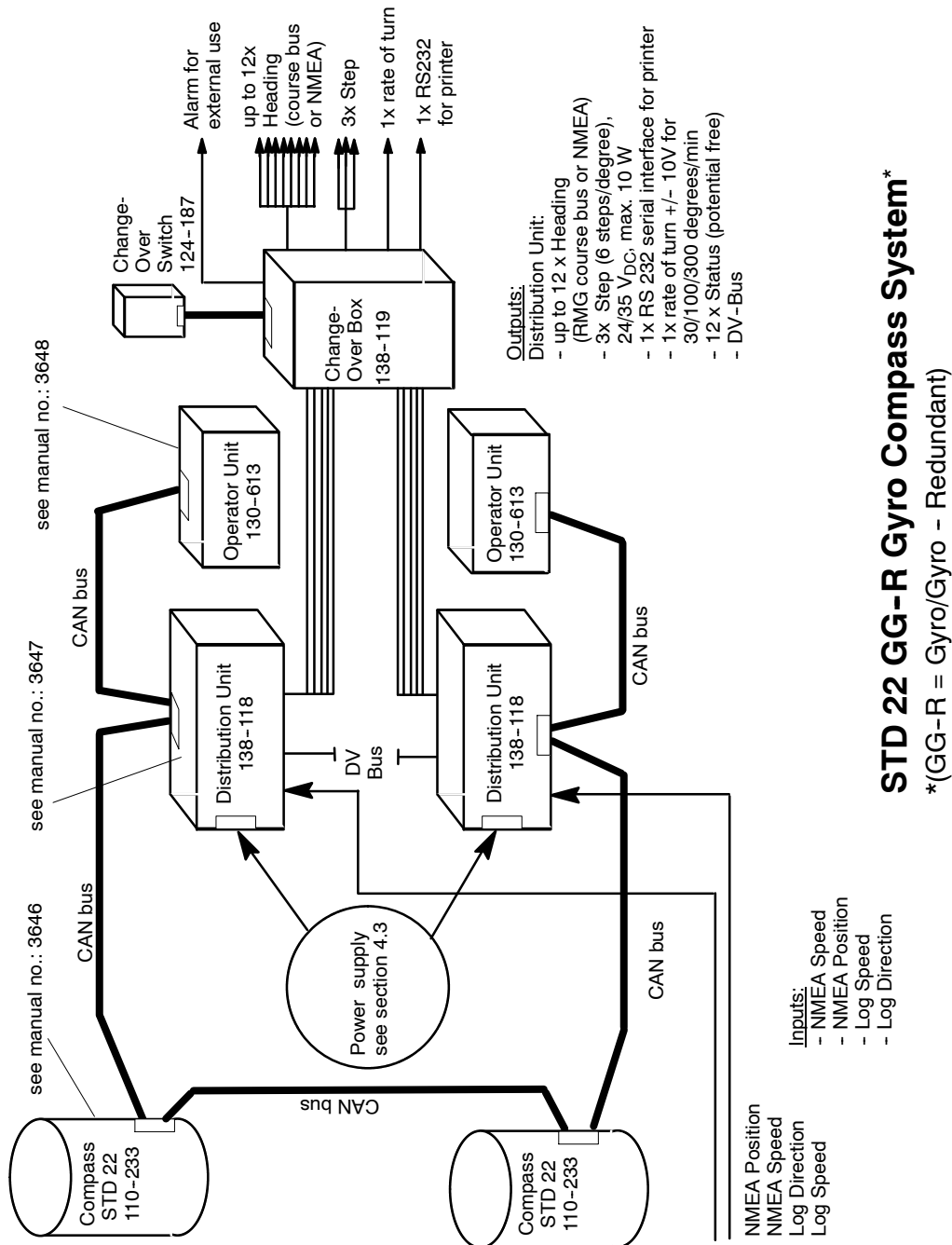

Figure 8: STD22 GG-R Gyro Compass - block diagram

Change Over Box
138-119



COMPASS
STD22

If an error occurs in the DU1 of the compass system1, the DU 1 generates an error message “System Failure” , in terms of a 24 V DC switch potential, to the Change Over Box. In the automatic mode this “System Failure” effects a switching-over from the outputs of DU 1 to the outputs of DU 2.

The STD22 GG-R Gyro Compass System is equipped with a redundant power supply (see section 4.3 Redundant Voltage Supply).

Change Over Box 138-119

4.2 Change Over Box application in the STD22 GGM-R Gyro Compass System

The block diagram below shows a Change Over Box and a Change Over Switch in the STD22 GGM-R Gyro Compass System (GGM-R = Gyro/Gyro/Magnet - Redundant) (see also block diagram 10-BD-D-X00014-C).

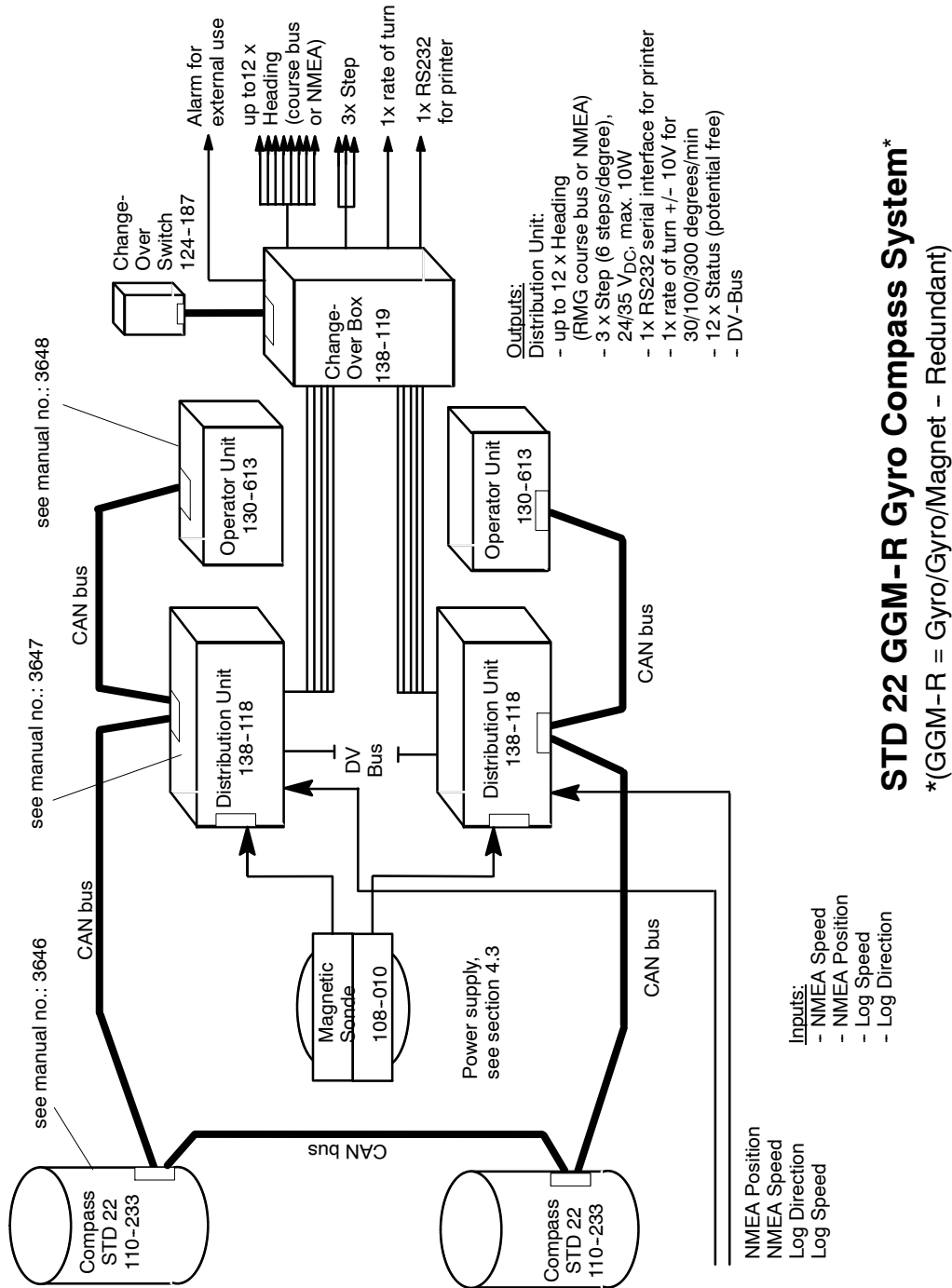

Figure 9: STD22 GGM-R Gyro Compass - block diagram

Change Over Box
138-119



COMPASS
STD22

The used Magnetic Sonde has to be a Twin Magnetic Sonde. It means: Each Compass system has to have an independent Magnetic Sonde.

If an error occurs in the DU1 of the compass system1, the DU 1 generates an error message "System Failure" , in terms of a 24 V DC switch potential, to the Change Over Box. In the automatic mode this "System Failure" effects a switching-over from the outputs of DU 1 to the outputs of DU 2.

The STD22 GGM-R Gyro Compass System is equipped with a redundant power supply (see section 4.3 Redundant Voltage Supply).

Change Over Box 138-119

4.3 Redundant Voltage Supply

A redundant power supply is implemented in the Compass systems (STD 22 GG-R and STD22 GGM-R). It consists of two power supplies “cross wired”. Block diagram below shows the principle of supplying at the example of STD22 GG-R (see also block diagram 10-BD-D-X00013-C).

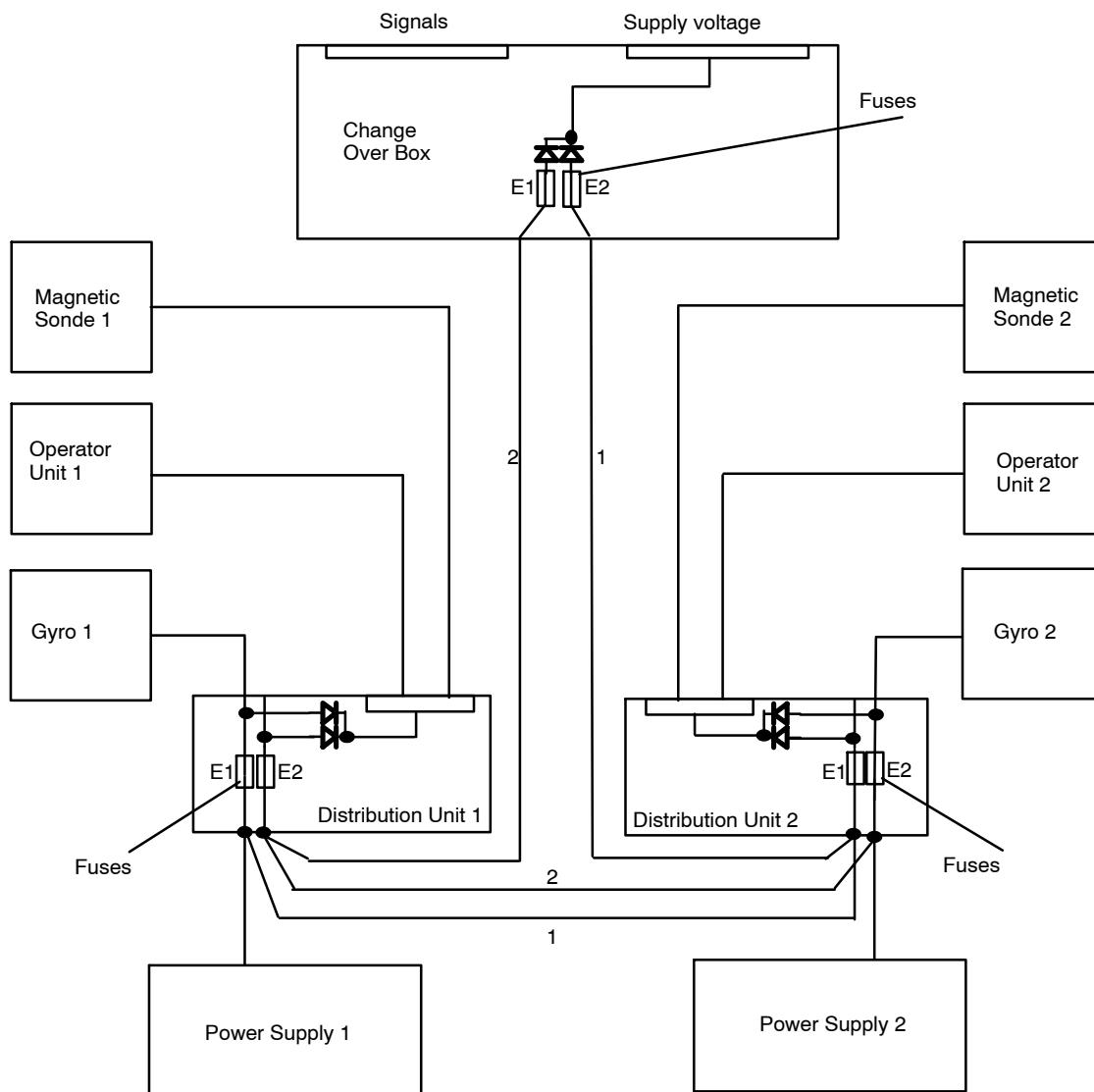
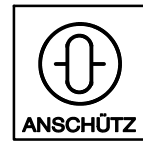

Figure 10: Redundant Power Supply in a STD 22 system - Principle-

Change Over Box
138-119



COMPASS
STD22

Example:

If power supply 1 fails all in the system1 connected devices (Magnetic Sonde 1, Operator Unit 1 and Distribution Unit 1) are supplied with the necessary voltage from power supply 2 (via the Distribution Unit 2).

The Change Over Box is supplied with operating voltage via both Distribution Units furthermore.



NOTE:

This Gyro which is connected to that Distribution Unit whose connected power supply fails, is no longer supplied with operating voltage.

Change Over Box 138-119

4.4 Error message “System Failure”

4.4.1 “System Failure” in switch position “Automatic”

If the Distribution Unit 1 fails, an error message, which leads to a switch-over in the Change Over Box, is output from the DU 1.

Condition for that is a normal operating mode of the Compass systems and a switch position “Automatic” of the Change Over Switch.

	<p>NOTE! A failure in the compass system 2 and a generation of an error message in the Distribution Unit does not lead to a switch-over of the Change Over Box.</p>
---	--

Cause of an error message can be below mentioned disturbances:

1. Internal CAN bus of the DU 1 failed.
2. Voltage drop of two monitored voltages (extern, output) in the DU 1.
3. Complete breakdown of the DU 1.

All above mentioned errors or combinations thereof, will lead to a “System Failure” in the DU 1.

This “System Failure” activates a closing of a relay contact in the DU 1.

By this an electrical circuit is closed in the Change Over Box and all relays are connected to 24 V DC switching potential. All relays of the Switch over Box are caused to activate and switch-over the output from DU 1 to DU 2.

Error recognition:

The activation of the error “System Failure” of the DU 1 can be gripped off and can be used to control external devices. This error message is at the terminal board of the Change Over Switch.

If the failure has been repaired and the compass system has been set into operation again, the complete system operates automatically in the normal mode:

- The “System Failure” -relay is dropped off.
- There is no switching potential at the relays of the Change Over Box.
- All relays of the Change Over Box are dropped off.
- The outputs of the Distribution Unit are output from the Change Over Box.

4.4.2

“System Failure” in switch positions “Sys1” and “Sys2”

	<p>ATTENTION! In case of a failure in Distribution Unit 1 (“System Failure”) and with the Change over Switch in Position “Sys1” or “Sys2” there is no automatic switch-over to the other Distribution Unit.</p>
---	--

If the Change Over Switch is in position “Sys1” or “Sys2”, there is no automatically switch-over function!

- In position “Sys1” only signal outputs of the compass system 1 are switched to the outputs of the Change Over Box.
- In position “Sys2” only signal outputs of the compass system 2 are switched to the outputs of the Change Over Box.

Change Over Box 138-119

4.4.3 Status messages/Error messages

The Distribution Unit provides other status messages:

- System Failure (is used to switch-over all relays of the Change Over Box)
- Sensor Alarm Gyro1 Failure
- Sensor Alarm Gyro2 Failure
- Sensor Alarm Gyro3 / GPS Failure
- Sensor Alarm TMC Failure
- Course Monitor Alarm
- Sensor Diff. Alarm
- TMC Selected
- Gyro Selected
- GPS Gyro Selected
- CAN BUS Failure
- Alarm reset



All above mentioned status messages and/or alarms can be output out of each Distribution Unit and can be indicated at external alarm devices/systems.

Only the “System Failure” of Distribution 1 switches the relays of the Change Over Box.

If a “System Failure” occurs in the Distribution Unit 1, all other status messages and/or alarms of the Distribution Unit 1 are without interest.

If a “System Failure” occurs in the Distribution Unit 2, all other status messages and/or alarms of the Distribution Unit 2 are without interest.



The DV bus, which is also output from a Distribution Unit is not switched-over.

For further information on the status messages of the Distribution Unit see manual of the Distribution Unit.



The blackout of a Distribution Unit is not displayed at the Operator Units.

Therefore it is constraining necessary to connect the error message "System Failure" from each Distribution Unit to an external alarm device.

The error message "System Failure" is generated if a Distribution Unit is dropped out.

Change Over Box 138-119

5 Maintenance and Repair

5.1 Maintenance

Relays are electromechanic components, their function has to be tested sporadically (see 3.4 Function test).

	<p>ATTENTION! Do <u>not</u> perform this function test during a sea trial.</p>
---	---

5.2 Repair

5.2.1 Safety instructions

	<p>ATTENTION! Pay attention whilst Maintenance and Repair at electrical devices. Avoid contact with cable under load. Adhere respective safety regulations, as there are VDE, BGV A2, OSHA 1919 and other national and international safety standards.</p> <p>ATTENTION! Maintenance and Repair have to be performed only by trained personnel, which is familiar with the safety requests of this device. Removal of spare parts is not allowed at a system under load.</p>
---	--

	<p>ATTENTION! All repair measures are carried out only after clearance with the ship's command.</p>
---	--



5.2.2 Trouble shooting in a STD 22 Gyro Compass System

The Change Over Box accomplishes a defined task within a complete STD22 Compass system.

Failures in other parts of the equipment have an effect on the complete system.

By this a trouble shooting makes only sense under consideration of the complete compass system.

5.2.3 Fuses in the Change over Box

At the terminal board of the Change over Box 13 terminal are protected with fuses (see also appended wiring diagram).

	Terminal/Application	Fuse
(1)	Supply Voltage Change over Box	E1 6,3 A 250 V
(2)	Supply voltage Change over Box	E2 6,3 A 250 V
3	Supply voltage Repeater	E3 1 A L 250 V
4	Supply voltage Repeater	E4 1 A L 250 V
5	Supply voltage Repeater	E5 1 A L 250 V
6	Supply voltage Repeater	E6 1 A L 250 V
7	Supply voltage Repeater	E7 1 A L 250 V
8	Supply voltage Repeater	E8 1 A L 250 V
9	Supply voltage Receiver	E9 1 A L 250 V
10	Supply voltage Repeater	E10 1 A L 250 V
11	Supply voltage of additional receivers	E11 2 A L 250 V
12	Supply voltage of additional receivers	E12 2 A L 250 V
13	Supply voltage of additional receivers	E13 2 A L 250 V

Change Over Box 138-119

5.2.4 Service



ATTENTION!

Devices can be faulty.

While exchanging electrical components the equipment has to have zero potential.



NOTE!

While closing again the housing after a repair or an installation, the cover has to be set carefully.

The seal may not be crushed, if necessary push the sidewall slightly.

After accomplishment of a service a setting to work procedure and a function test has to be done again (see section 3.3 Setting to work and 3.4 Function test).

5.2.4.1 Exchanging of Fuses



CAUTION!

Use only fuses with prescribed technical data (see parts list at the wiring diagram).

Do not replace fuses under load.

The fuses E1 to E13 are located at the terminal board L1 of the Change Over Box (see wiring diagram 138-119.HP008).

If one of the fuses E1 or E2 blows, the system status is according to switch position "Sys1", it means the output signals of the Distribution Unit 1 are fed to the Change Over Box.



If both fuses (E1 and E2) are blown, all receivers which are supplied via the Change Over Box are no longer supplied with operating voltage.

1. Switch OFF both power supplies (disconnection from ship's mains).
2. Unscrew the cover of the housing.
3. Remove blown fuse out of the fuse holder.
4. Insert new fuse (attend the correct type).
5. Screw on the cover again and pay attention to a proper position of the sealing.
6. Switch ON both power supplies.

Change Over Box 138-119

5.2.4.2 Exchanging of relays

1. Switch OFF both power supplies (disconnection from ship mains).
2. Unscrew the cover of the housing.
3. Tag the signal- and supply lines of the respective relay and unscrew them from the relay terminals.
4. Protect wires against contact.
5. Detach the clamp retention of the relay and replace the relay.
6. Fix the destination label at the relay.
7. Plug the signal- and supply lines into the respective terminals and tighten them.
8. Screw on the cover again and pay attention to a proper position of the sealing.
9. Switch ON both power supplies.

5.3 Parts list

A complete list of spare parts is shown at the wiring diagram for the Change Over Box 138-119.HP008 and for the Change Over Switch at the Dimensional Drawing 124-187.HP005.

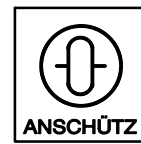

6 Error performance

Following considerations will show the reaction in case of a fail of a GG-R system (Gyro/Gyro redundant) or a GGM-R system (Gyro/Gyro/Magnet redundant) with a connected Change over Box.

These considerations exclude wrong cable connections or broken cable.

At least a GG-R system consist of:	At least a GGM-R system consist of:
Gyro 1	Gyro 1
Gyro 2	Gyro 2
Distribution Unit 1	Distribution Unit 1
Distribution Unit 2	Distribution Unit 2
Power Supply 1	Power Supply 1
Power Supply 2	Power Supply 2
Change over Box	Magnetic sonde 1
Change over Switch	Magnetic sonde 2
	Change over Box
	Change over Switch

Both Operation Units are not significant to the error performance in this considerations, because of their function does not effect the redundancy.

The Change over Box is also not significant to the error performance, because of there is no redundancy in case of their fail.

It is to assume in the following considerations that:

- The Change over Box operates always with switch position "Automatic".
It means that in the normal operation mode the outputs of the Distribution Unit 1 are forwarded via the Change over Box.
Other switch positions (position 1 or position 2) are acceptable only in exceptional cases.
- The automatically switch-over function G/G and G/M are always active.
- Gyro 1 is always the selected sensor.

Change Over Box 138-119

Error performance	System GG-R	System GGM-R
Gyro 1 fails	see section 6.1	see section 6.1
Gyro 2 fails	see section 6.2	see section 6.2
Distribution Unit 1 fails	see section 6.3	see section 6.3
Distribution Unit 2 fails	see section 6.4	see section 6.4
Power Supply 1 fails (connected to Distribution Unit 1)	see section 6.5	see section 6.5
Power Supply 2 fails (connected to Distribution Unit 2)	see section 6.6	see section 6.6
Magnetsonde 1 fails (connected to Distribution Unit 1)		see section 6.7
Magnetsonde 2 fails (connected to Distribution Unit 2)		see section 6.8

6.1

Gyro 1 fails

If the automatic switch-over function G/G is selected (see manual for Operator Unit), the system (Distribution Unit) switches-over immediately to Gyro 2.

If this function is not selected, a manual switch-over to Gyro 2 has to be carried out.

The message "Switched to GY2" is displayed only, if the automatic switch-over function is selected.

An alarm is generated acoustical and optical and has to be acknowledged (see manual for Operator Unit).

This error message "Gyro 1 Failure" can be detached from the Distribution Unit and forwarded to external alarm devices (detached from the Change over Box too - if connected).

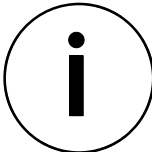
	<p>After a RESET of the complete system and Gyro 1 still fails, the Gyro 2 is designated as Gyro (the numerical indication is no longer displayed).</p> <p>After a repair is to pay attention that the repaired Gyro is integrated into the system with the lowest CAN bus address again - otherwise it will not be identified as Gyro 1.</p>
---	---

An automatically switch-over to Magnetic Sonde is only possible if both Gyros fail.

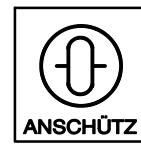

6.2 Gyro 2 fails

If Gyro 2 fails (not selected as heading sensor) a “silent alarm” is generated. It means that the Gyro 2 is indicated as “failed” at the Operator Unit, but there is no acoustic alarm.

The error message “Gyro 2 Failure” can be detached from the Distribution Unit and forwarded to external alarm devices (detached from the Change over Box too - if connected).

After repair the “silent alarm” is cancelled.

6.3 Distribution Unit 1 fails

The Change over Box switches over to the Distribution Unit 2 at once. The release of that switching-over is the generation of the error message “System Failure” from the Distribution Unit 1. It means that the outputs of Distribution Unit 2 are forwarded from the Change over Box.

This fail is not displayed at the Operator Unit.

An external connected alarm device shows the message “System Failure”.

6.4 Distribution Unit 2 fails

The system stays in the actual operation mode. The active Distribution Unit 1 controls the system.

This fail is not displayed at the Operator Unit.

An external connected alarm device shows the message “System Failure”.

Change Over Box 138-119

6.5 Power Supply 1 fails

Both Power Supplies are “cross” connected at both Distribution Units.

If the Power Supply 1 (connected at the Distribution Unit 1) fails, the Distribution Unit 1 is supplied by the Power Supply 2 (connected at the Distribution Unit 2).

In a GG-R system the Change over Box, both Operator Units and both Distribution Units are supplied by the Power Supply 2.

In a GGM-R system the Change over Box, both Operator Units, both Distribution Units and both Magnetic Sondes are supplied by the Power Supply 2.



Gyro 1 is no longer supplied with operating voltage
(see also section 6.1 “Gyro 1 fails”).

6.6 Power Supply 2 fails

Both Power Supplies are “cross” connected at both Distribution Units.

If the Power Supply 2 (connected at the Distribution Unit 2) fails, the Distribution Unit 2 is supplied by the Power Supply 1 (connected at the Distribution Unit 1).

In a GG-R system the Change over Box, both Operator Units and both Distribution Units are supplied by the Power Supply 1.

In a GGM-R system the Change over Box, both Operator Units, both Distribution Units and both Magnetic Sondes are supplied by the Power Supply 1.



Gyro 2 is no longer supplied with operating voltage
(see also section 6.2 “Gyro 2 fails”).

6.7 Magnetic Sonde 1 fails

The Course Monitor function is no longer present.

This error messages “TMC Failure” and “Course Monitor Alarm” can be detached from the Distribution Unit and forwarded to external alarm devices (detached from the Change over Box too - if connected).

To adhere the course monitoring the Change over Switch has to be switched into position 2. In this case the Distribution Unit 2 is selected and the Course Monitor function is performed with the Magnetic Sonde connected to Distribution Unit 2.

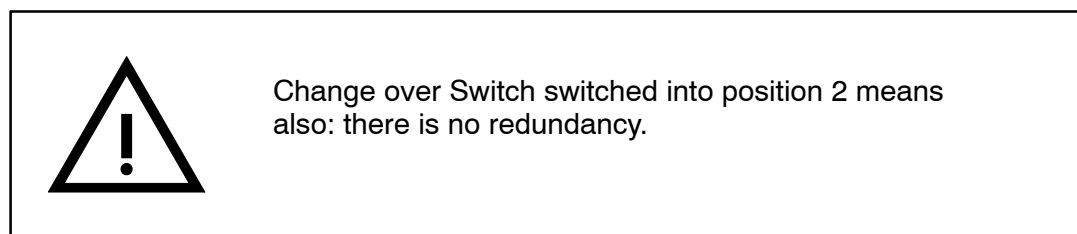

6.8 Magnetic Sonde 2 fails

The outputs of the active Distribution Unit are forwarded via the Change over Box.

The failed Magnetic Sonde 2 is connected at the Distribution Unit 2.

This fail is not displayed in the normal operating mode.

**Change Over Box
138-119**

intentionally left blank

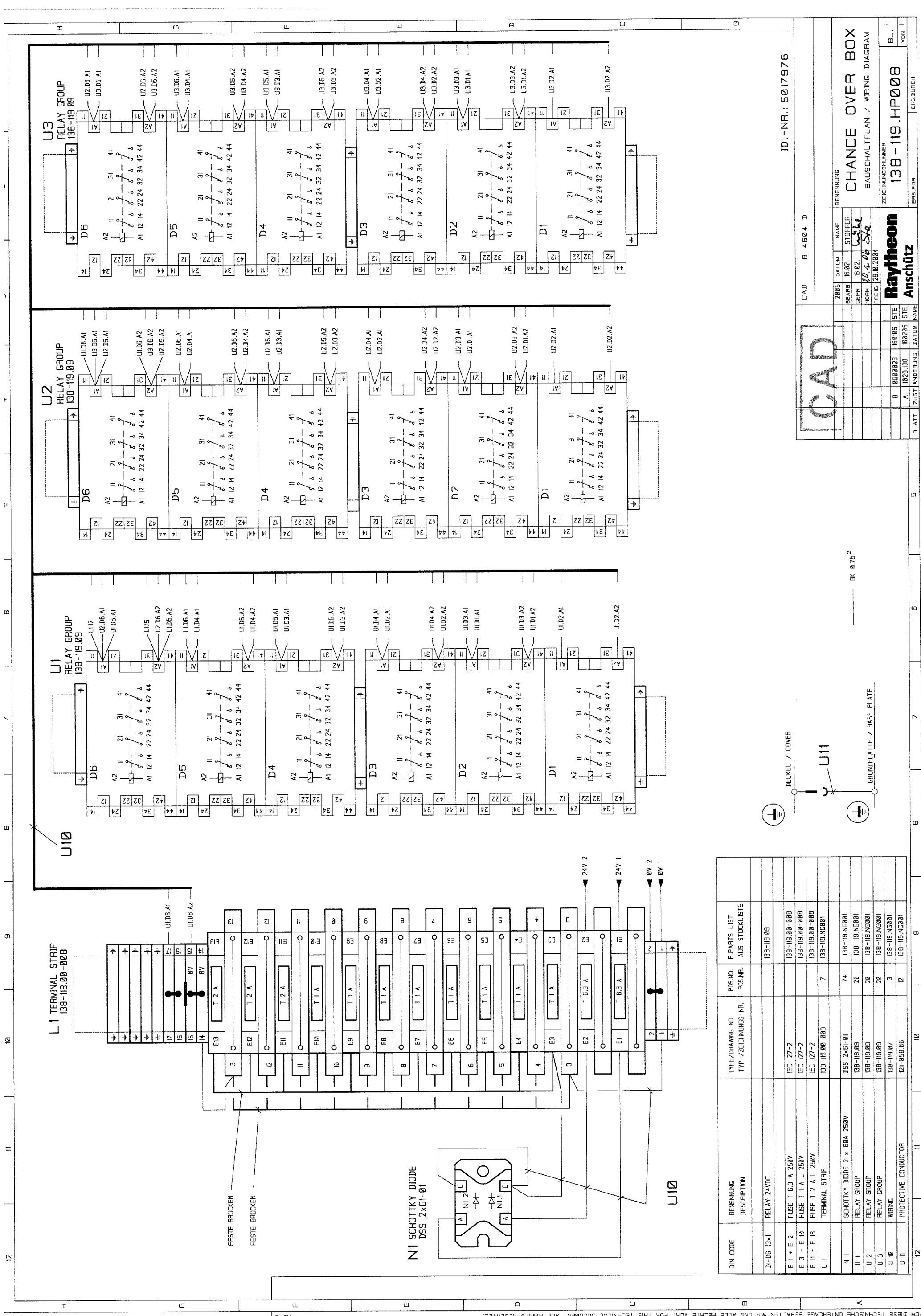

ID.-NR.: 5017976

BENENNUNG		CHANGE OVER BOX	
BAUSCHALTPLAN / WIRING DIAGRAM		ZEICHNUNGSNUMMER	
138-119.HP008		ERS.FÜR	
BL. 1		YDN 1	
CAD B 4504 D		DATEI	
2005	DATUM	NAME	STOFFER
BEARB	16.02.	U. K.	
GEPR	16.02.	U. K.	
NORM	10.1.04	U. K.	
FREIG	25.10.2004		
Raytheon		ANSCHÜTZ	
B	0502028	160105	STE
A	1025138	160205	STE
BLATT	ZUST	ÄNDERUNG	DATUM

CAD

BK 0,75²

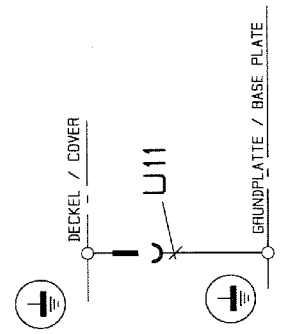

DIN CODE	BENENNUNG DESCRIPTION	TYPE/DRAWING NO. TYP-/ZEICHNUNGS-NR.	POS.ND. POS.NR.	F.PARTS LIST AUS STOCKLISTE
D1-D6 (3x)	RELAY 24VDC			138-119.09
E1 + E2	FUSE T 6,3 A 250V	IEC 127-2		138-119.00-008
E3 - E10	FUSE T 1 A L 250V	IEC 127-2		138-119.00-008
E11 - E13	FUSE T 2 A L 250V	IEC 127-2		138-119.00-008
L1	TERMINAL STRIP	138-119.00-008	17	138-119.N5001
N1	SCHOTTKY DIODE 2 x 60A 750V	D55 2x61-01	74	138-119.N5001
U1	RELAY GROUP	138-119.09	20	138-119.N5001
U2	RELAY GROUP	138-119.09	20	138-119.N5001
U3	RELAY GROUP	138-119.09	20	138-119.N5001
U10	WIRING	138-119.07	3	138-119.N5001
U11	PROTECTIVE CONDUCTOR	121-055.05	12	138-119.N5001

N1 SCHOTTKY DIODE
D55 2x61-01

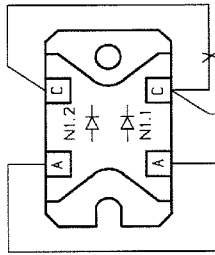

FESTE BRÜCKEN

FESTE BRÜCKEN

U10

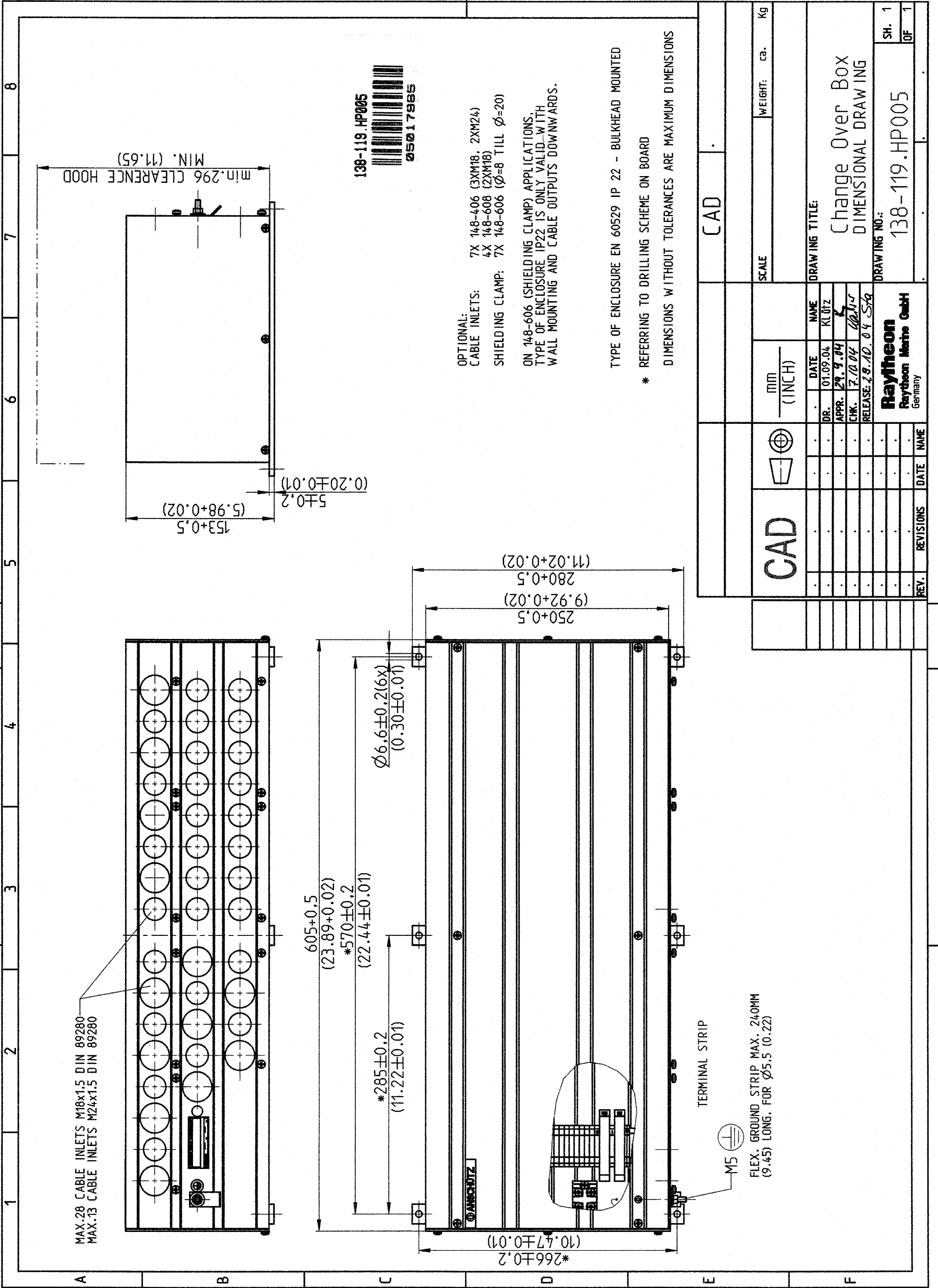

124-187.HP005

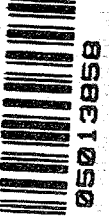

BACK VIEW "B1"

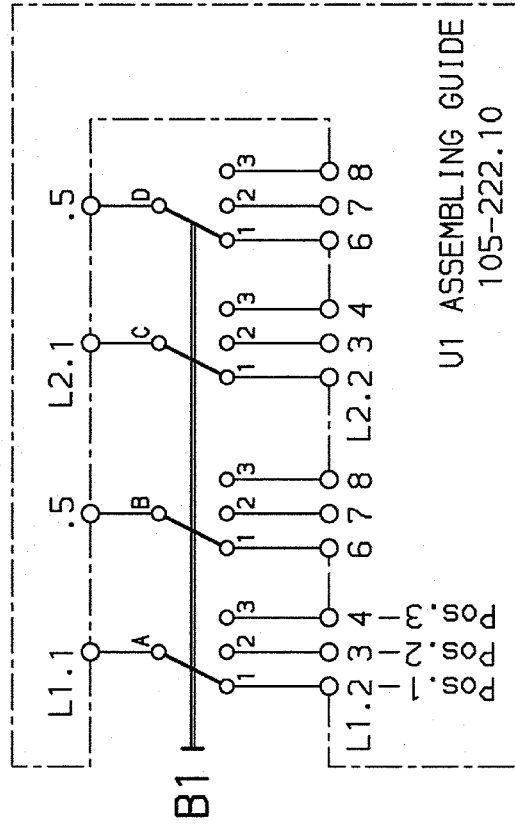
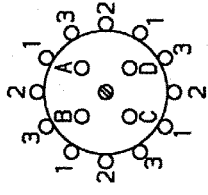

U1 ASSEMBLING GUIDE
105-222.10

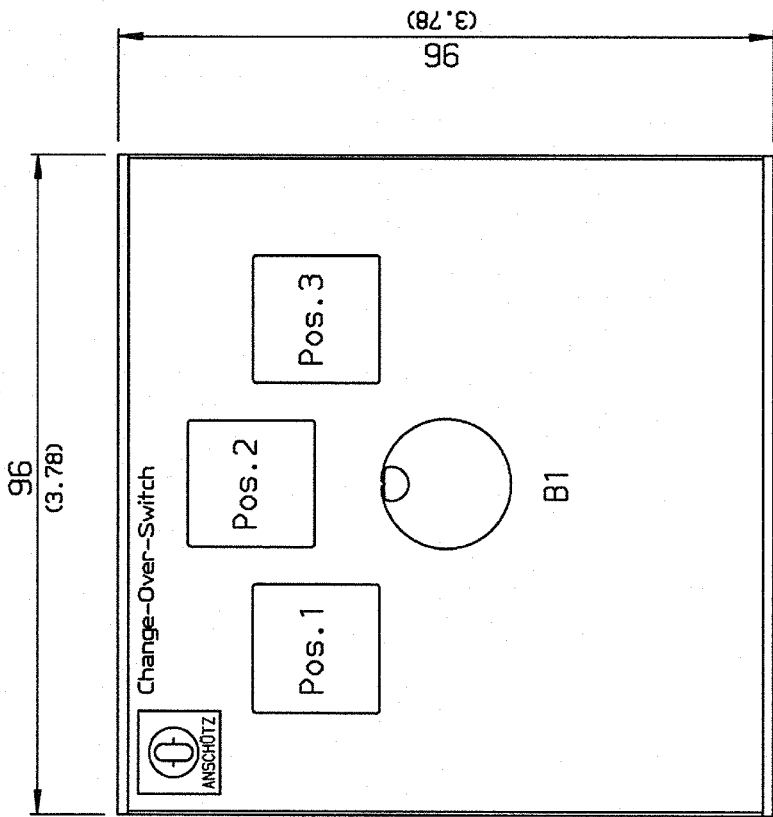

MOUNTING DEPTH

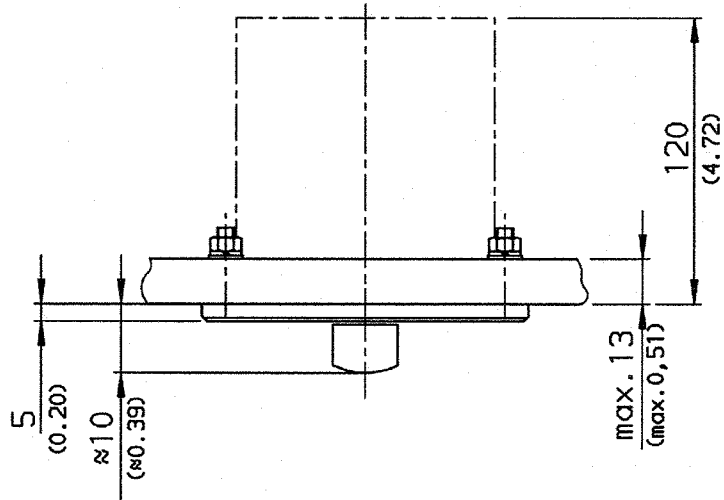

RECESS AND DRILLING SCHEME

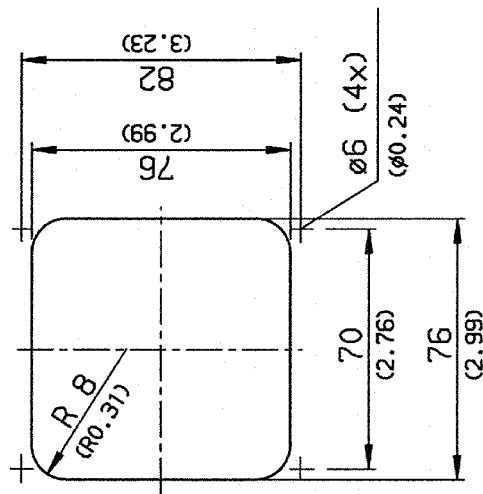

DIMENSIONS ONLY FOR INFORMATION
TYPE OF ENCLOSURE: EN 60529 IP23 AFTER INSTALLATION
DIMENSIONS WITHOUT TOLERANCES ARE MAXIMUM DIMENSIONS

Pos.	DESIGNATION	TYPE	NOTE
B1	SWITCH	NB14-231.00-017	.
U1	ASSEMBLING GUIDE	105-222.10	.
			.
			.
CORE CROSS OF CABLE : 0,5 mm ²			
DISTANCE FROM MAGNETIC COMPASS STANDARD TYPE :		STEERING TYPE :	
CAD		mm (INCH)	
2004	DATE	NAME	
05.10.	DR.	Henniger	
21.10.	APPR.	SA	
2.11.	CHK.	SA	
Freigabe: 17.09.02			
Raytheon Raytheon Marine GmbH Germany			
A	1228.124	05.10.04	Hen.
REV.	REVISIONS	DATE	NAME
DRAWING TITLE: DIMENSIONAL DRAWING CHANGE OVER SWITCH			DRAWING NO.: 124-187.HP005
SCALE :			WEIGHT: ...kg
SH. 1			OF 1

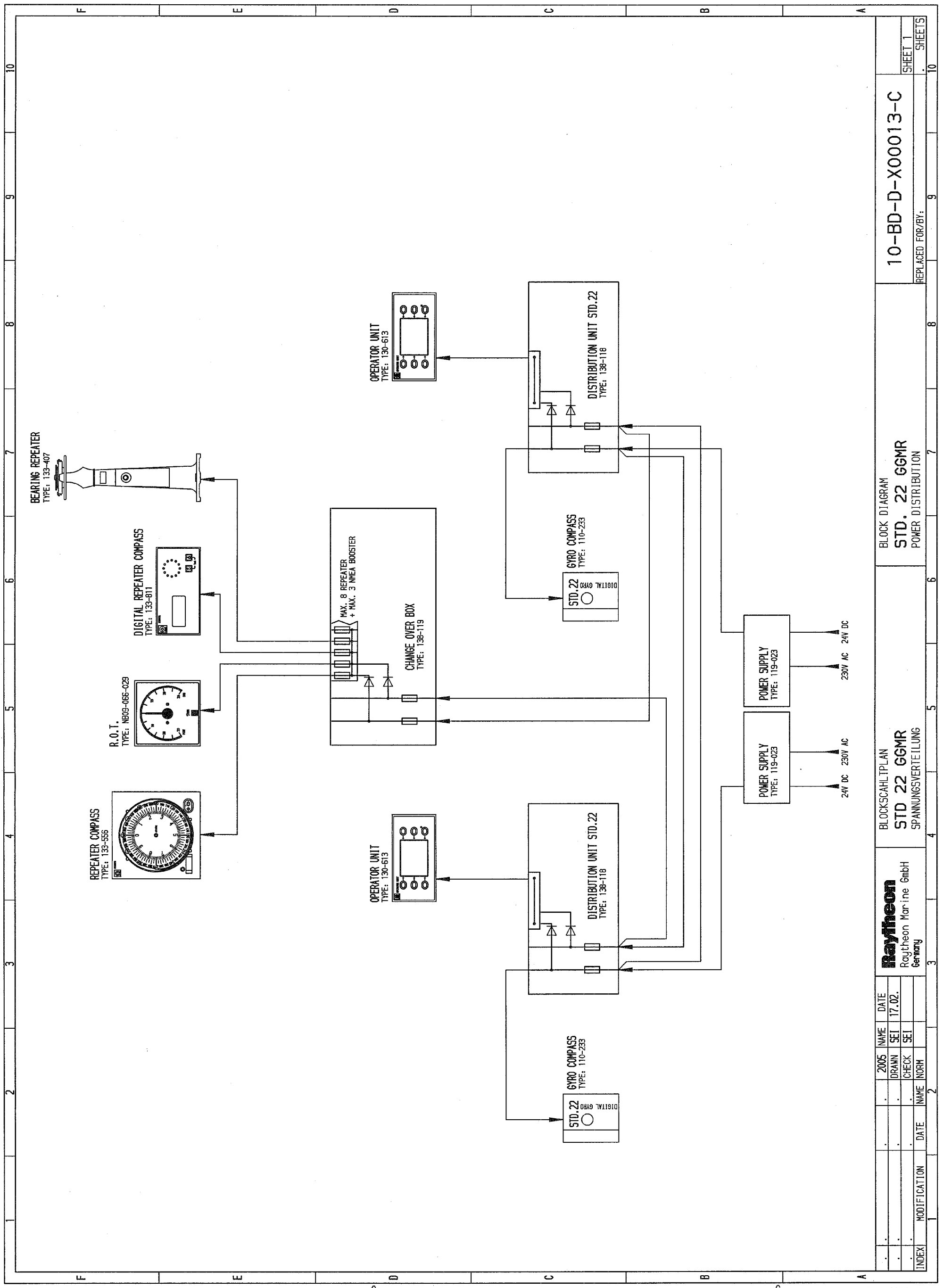

INDEX		MODIFICATION	DATE	NAME	2	3	4	5	6	7	8	9	10
2005	DRANN	CHECK	17.02.	SEI									
<p>Raytheon Raytheon Marine GmbH Germany</p>													
BLOCKSCHAHLTPLAN				BLOCK DIAGRAM				<p>STD 22 GGMR SPANNUNGSVERTEILUNG POWER DISTRIBUTION</p>					
10-BD-D-X00013-C													
REPLACED FOR/BY:													
SHEET 1													
SHEETS													

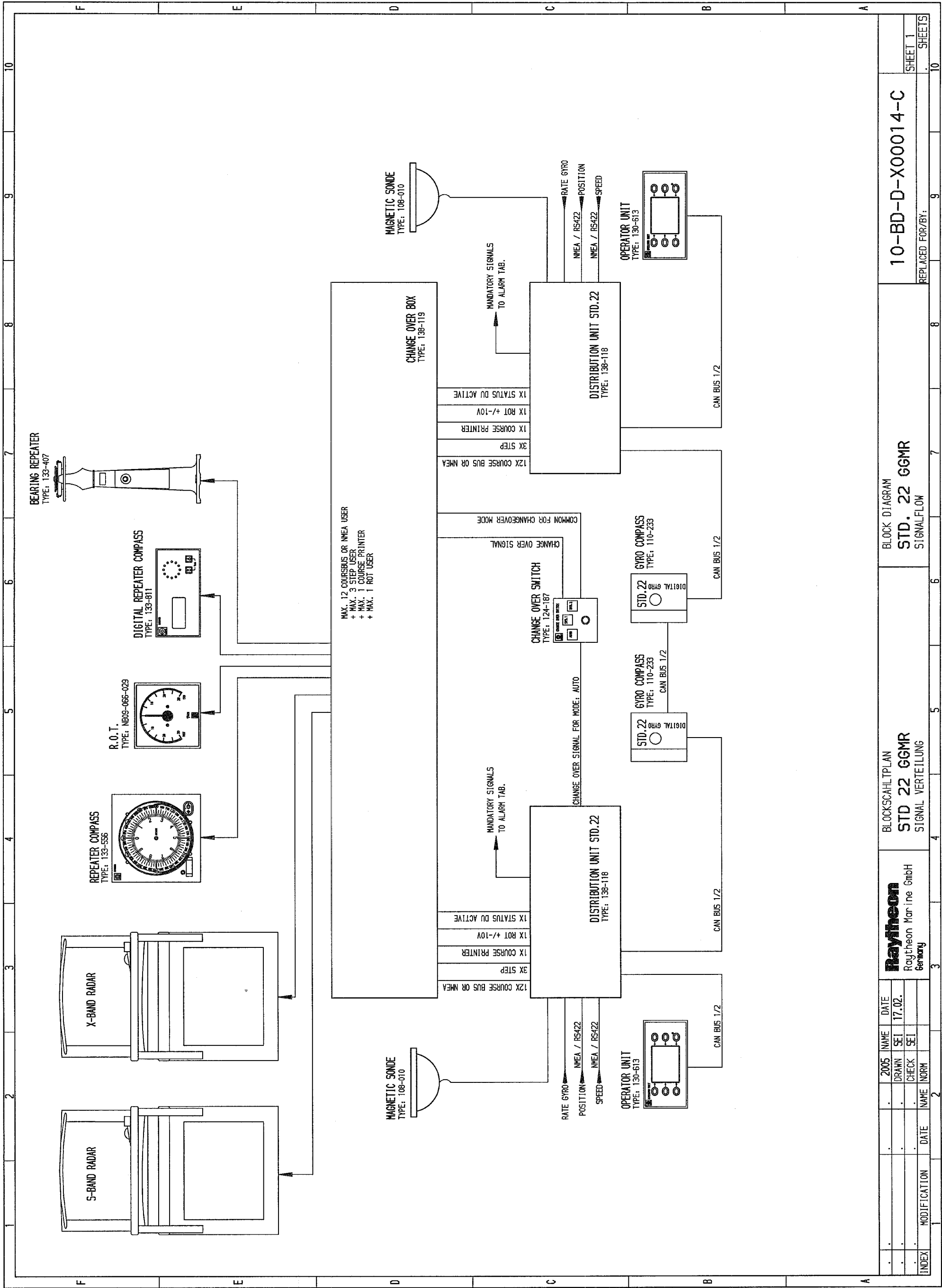

INDEX	MODIFICATION	DATE	NAME	NORM	2	3	4	5	6	7	8	9	10
			2005	NAME	DATE								
			DRANN	SEI	17.02.								
			CHECK	SEI									

Raytheon
Raytheon Marine GmbH
Germany

BLOCKSCAHLPLAN
STD 22 GGMR
SIGNAL VERTEILUNG

BLOCK DIAGRAM
STD. 22 GGMR
SIGNALFLOW

10-BD-D-X00014-C

SHEET 1
SHEETS

REPLACED FOR/BY: