

SAILOR 6248 VHF

What's in the box?

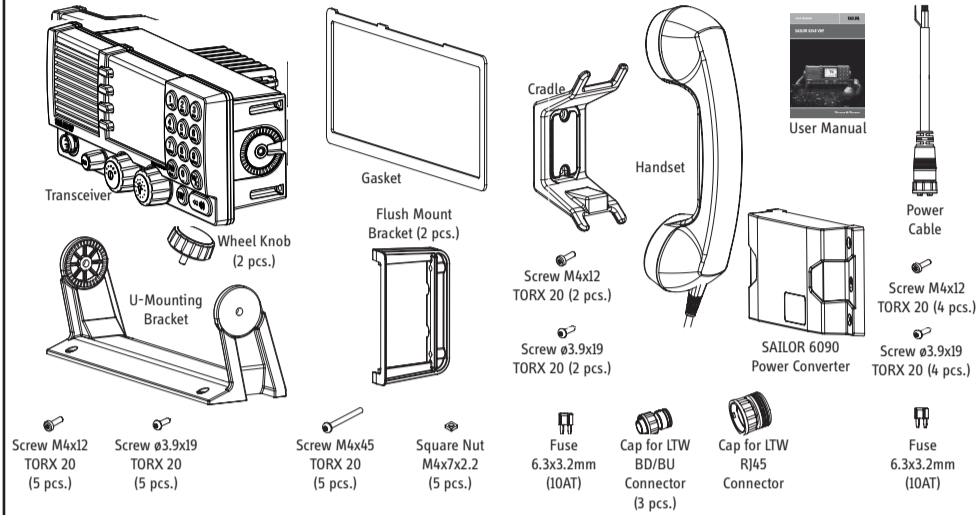

Dimensions for the VHF

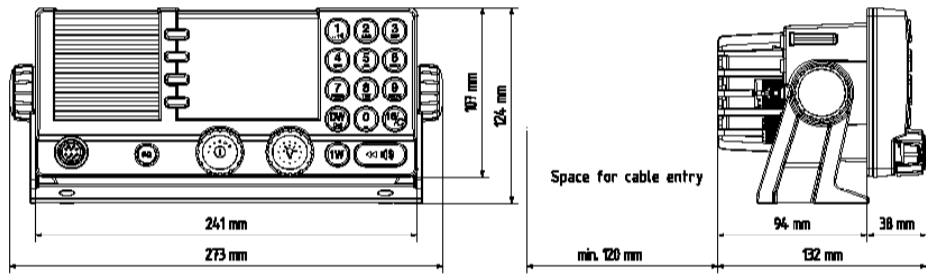

How to install the VHF on desktop and overhead

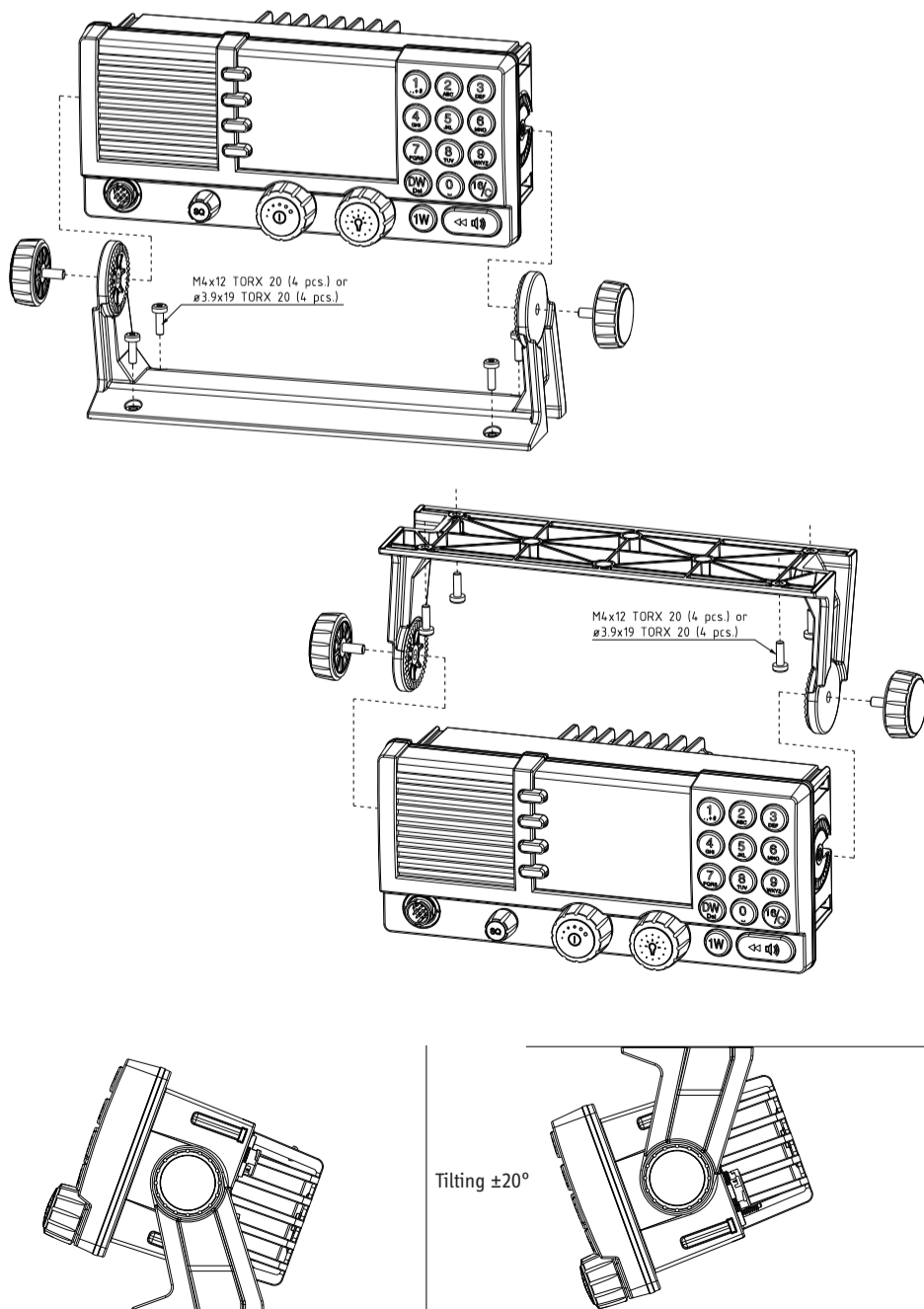

How to install the VHF flush mount

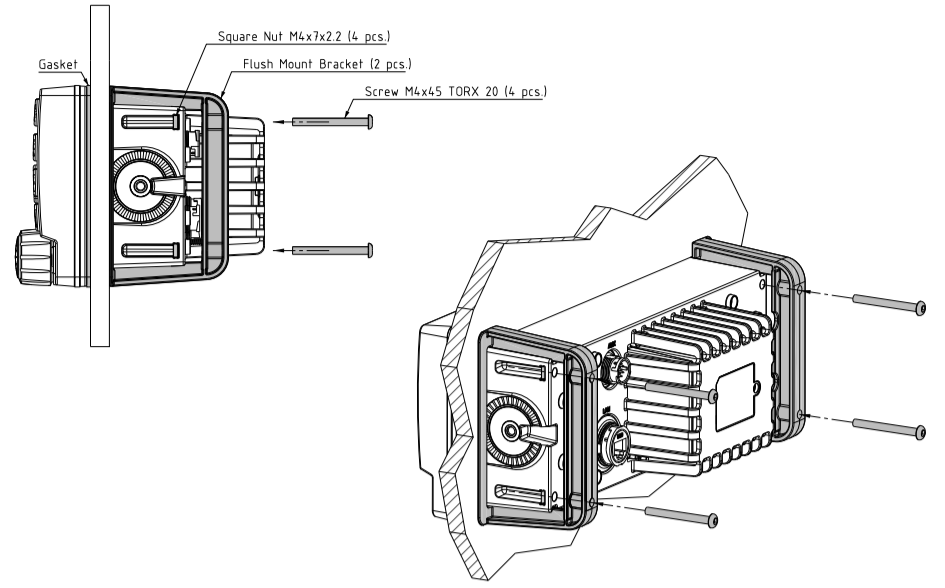

How to prevent water ingress

Connector for Handset or Hand Microphone - If not used, put the cap from the ACC connector on the front connector to prevent water ingress.

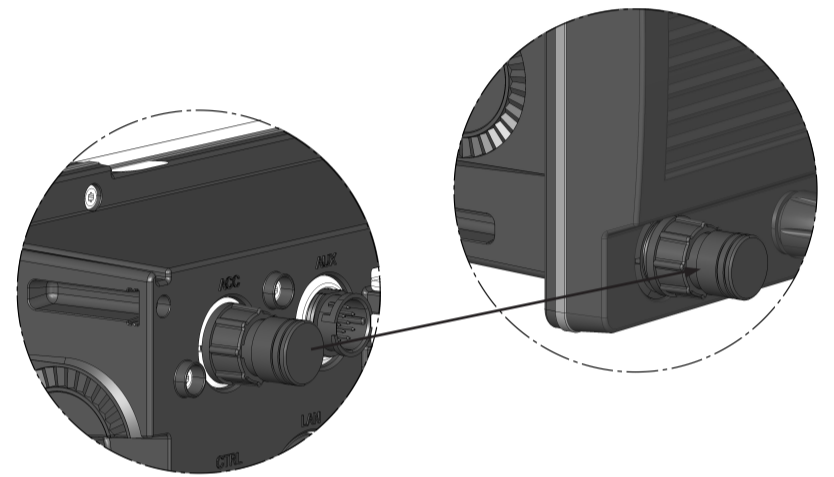

Very important information!

Do not remove the membrane. If you remove the membrane the radio will not be waterproof.

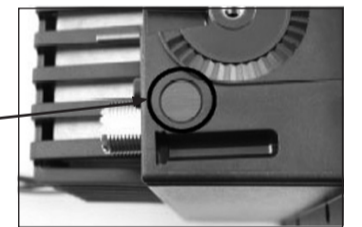

How to install the handset

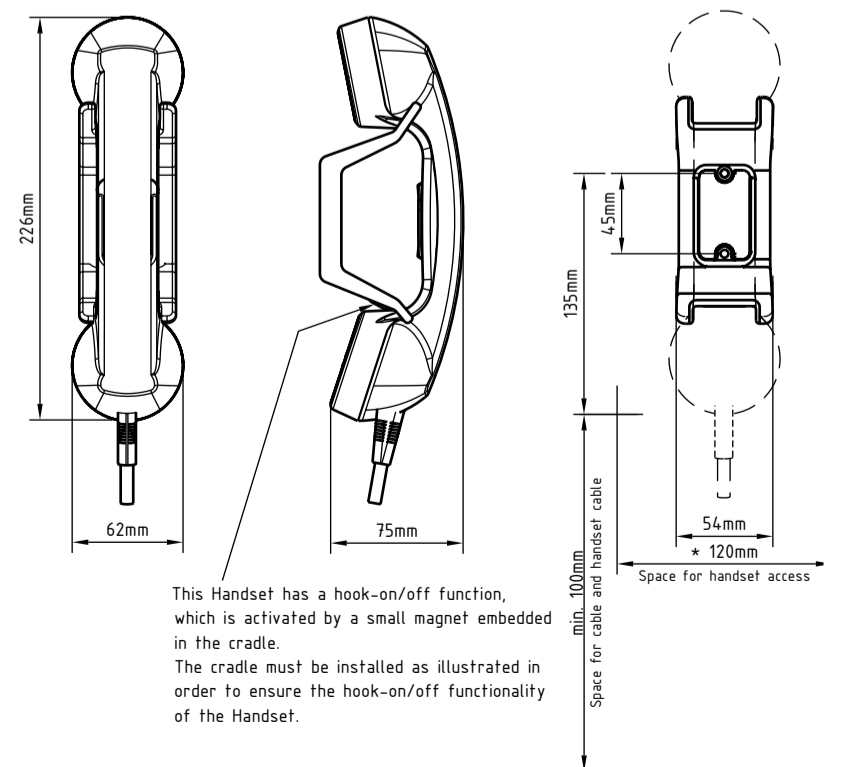

This Handset has a hook-on/off function, which is activated by a small magnet embedded in the cradle. The cradle must be installed as illustrated in order to ensure the hook-on/off functionality of the Handset.

Drilling plan on desktop and overhead

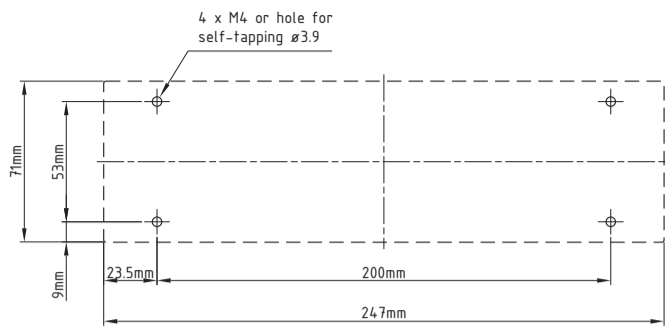

How to install the SAILOR 6090 Power Converter

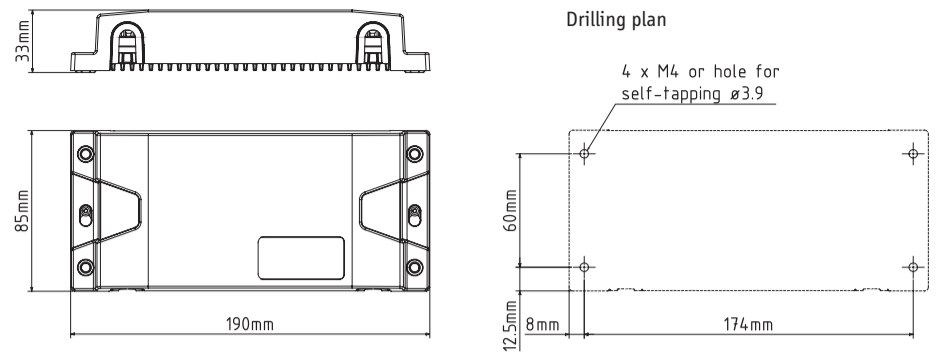

Cutout template for flush mounting of the VHF

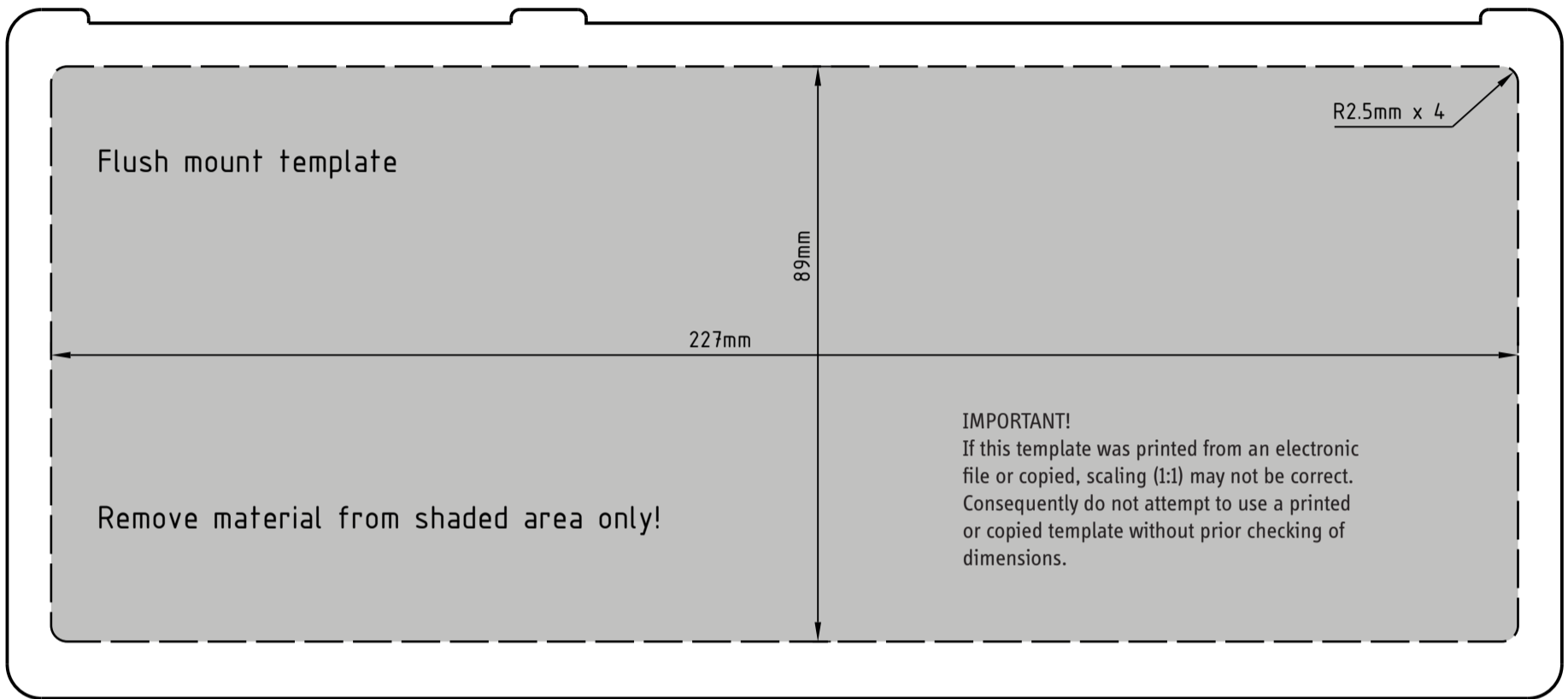

Scale 1:1

System Configuration - Example

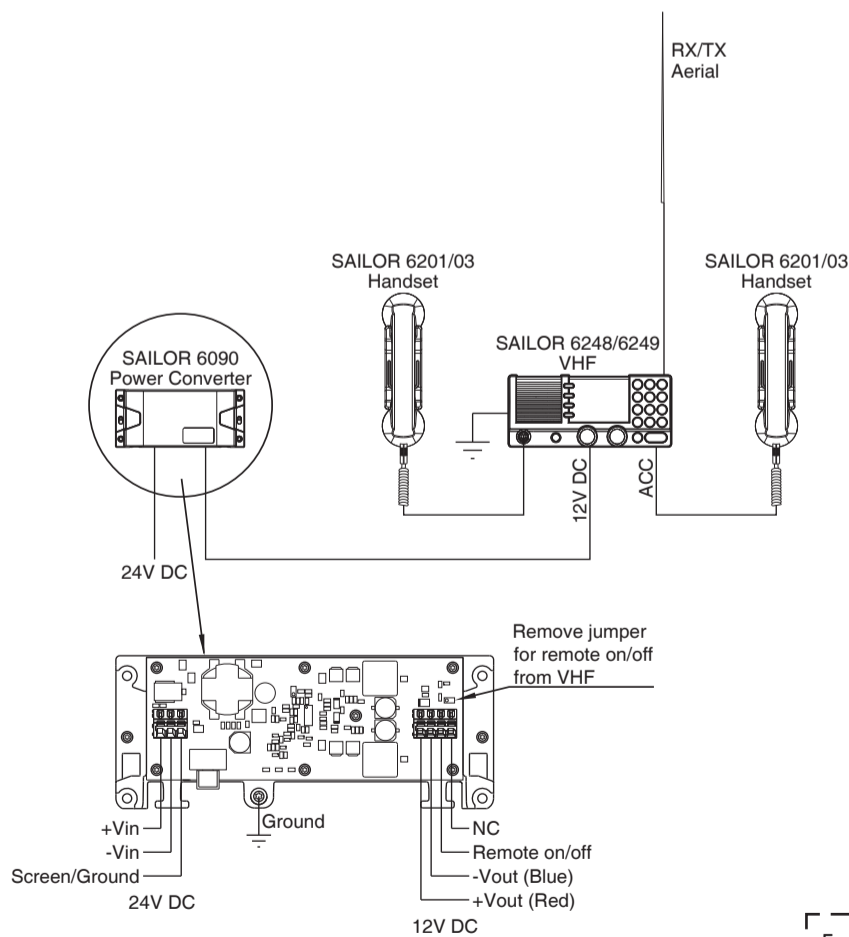

For further information, please download the installation manual part no. 98-135548 at <http://esupport.thrane.com>

99-133232-A

98-132282-B